

OUTLANDER

BODY REPAIR MANUAL

FOREWORD

This manual has been prepared for the use of all service mechanics engaged in the body repair service. Body dimensions, welded panel replacement procedures, body sealing application instructions, and all the other information required to provide quick and accurate body repair service are contained herein. One especially important point is the welding method. All of the vehicle's original strength and durability can be maintained by following the welding procedures contained in this manual.

Note that, in order to maximize the efficiency of the repair work, first, both the extent of the damage and the replacement parts that are needed must be calculated accurately, and then the actual work must be performed accurately and efficiently.

The publications shown below are also available, and should be used in conjunction with this manual.

TECHNICAL INFORMATION MANUAL	LNZE03E1
WORKSHOP MANUAL	
CHASSIS GROUP	CNZE03E1
BODY REPAIR MANUAL (PASSENGER CARS & LIGHT COMMERCIAL VEHICLES)	BNZE03E1
PARTS CATALOGUE	B606R503A

Mitsubishi Motors Corporation reserves the right to make changes in design and specifications and/or to make additions to or improvements in its products without imposing any obligation upon itself to install them on its products previously manufactured.

GROUP INDEX

GENERAL	0
BODY CONSTRUCTIONS.....	1
BODY DIMENSIONS	2
WELDED PANEL REPLACEMENT .	3
CORROSION PROTECTION.....	4
SYNTHETIC-RESIN PARTS	5
BODY COLOR	6
REFERENCE MATERIAL	8

CLICK HERE TO **DOWNLOAD** THE COMPLETE MANUAL

- Thank you very much for reading the preview of the manual.
- You can download the complete manual from: www.heydownloads.com by clicking the link below



- Please note: If there is no response to CLICKING the link, please download this PDF first and then click on it.

CLICK HERE TO **DOWNLOAD** THE COMPLETE MANUAL

Side Structure

A panel positioning notch has been added on the door opening to improve assembling workability when replacing the panel.

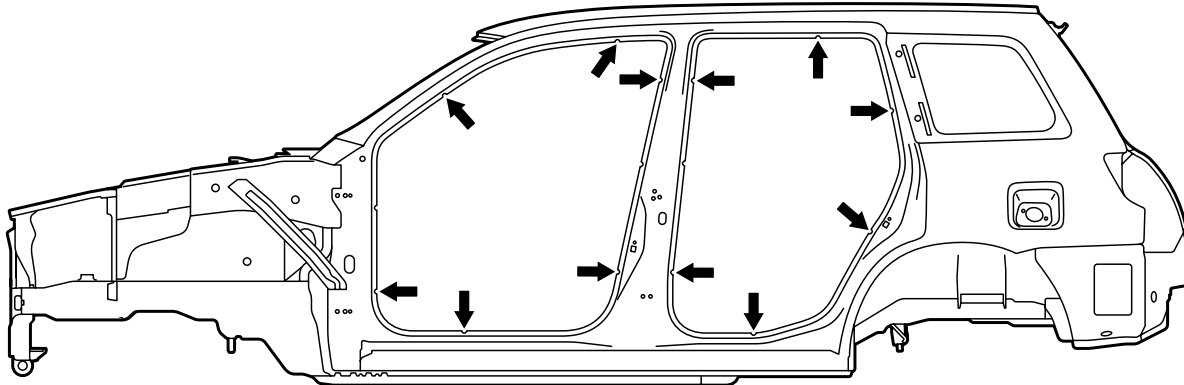
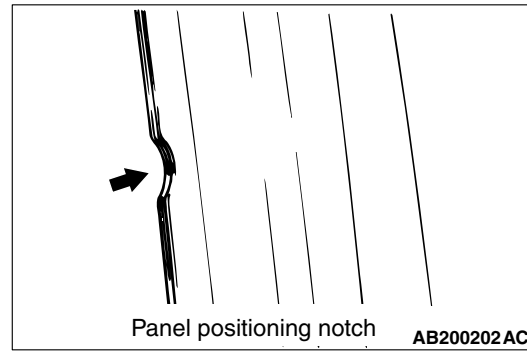

AB200007AC

Side Outer Panel

The extra parts are supplied in 4 different cut forms as a result of employing the integrated side-frame side outer panel.

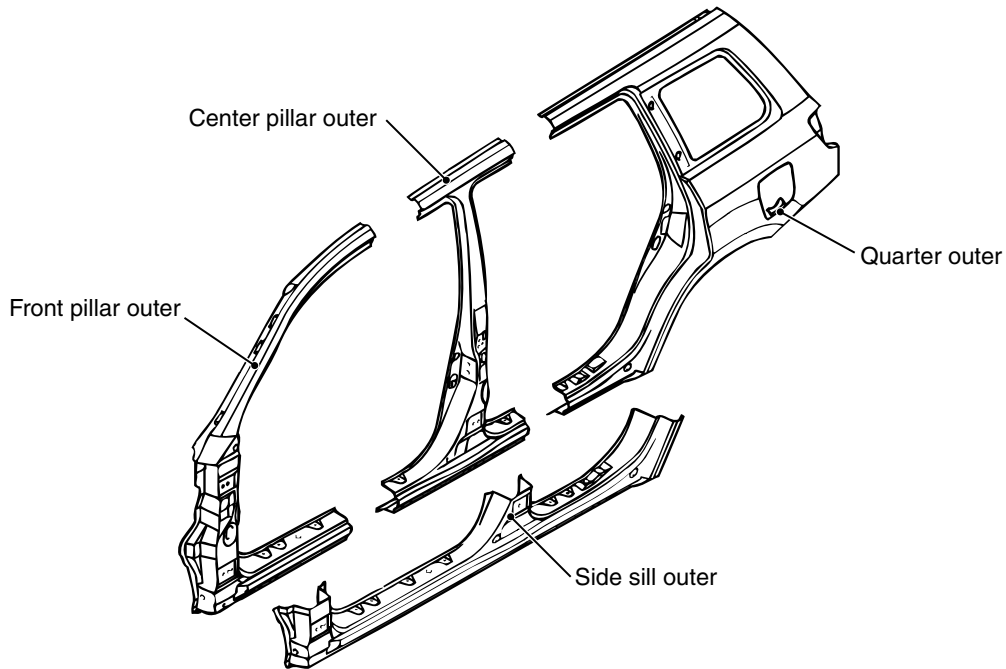

AB202352AB

REAR BODY

M4010012000106

Rear End Crossmember

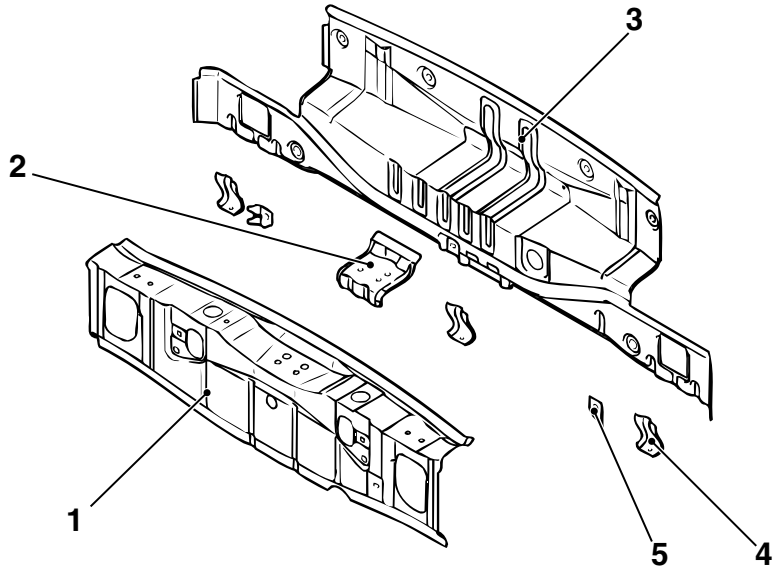

- 1. Rear end crossmember inner
- 2. Tailgate striker reinforcement
- 3. Rear end crossmember outer

- 4. Rear bumper bracket
- 5. Rear end outer plate

AB202349AH

STIFFENER AND DAMP SHEET APPLICATION LOCATIONS

M401008000125

Sound insulation was improved with anti-vibration effects and heightening surface rigidity with a stiffener on the inner side of the side outer panel, and front fender, as well as a damping sheet adhered to the inner side of the front door.

NOTE: The main contents of a stiffener are epoxy resin. It comes in a sheet form and contains a mixture of glass fiber and filler, and cures (stiffens) when heated. It is used to improve the rigidity of the outer plate.

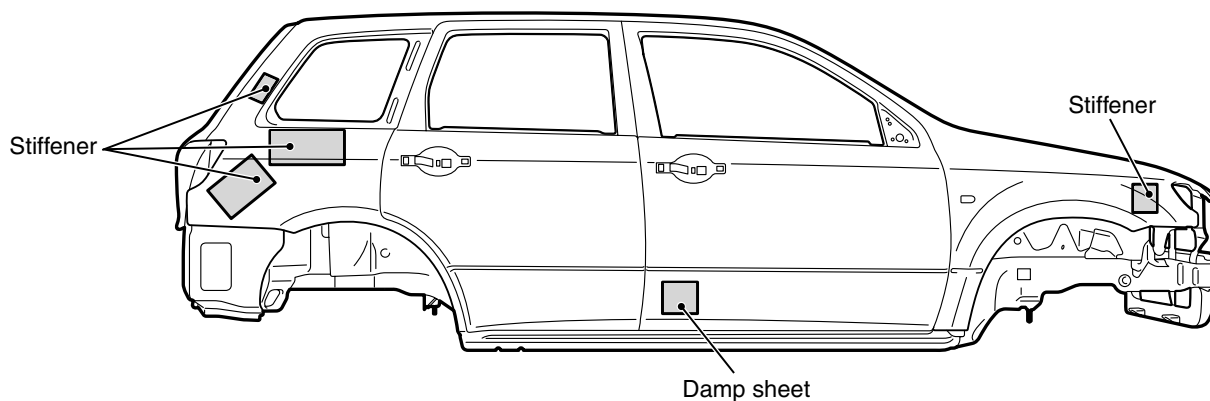
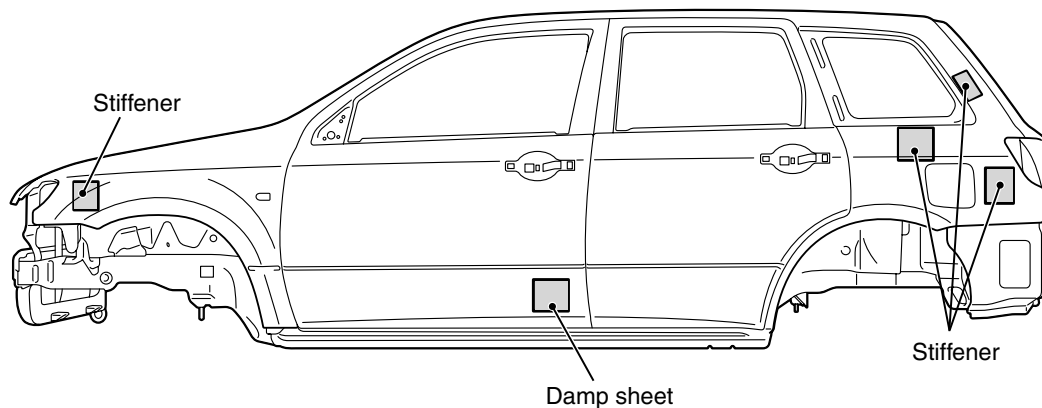

AB202330AB

BODY DIMENSIONS
TYPE B (ACTUAL-MEASUREMENT DIMENSIONS)

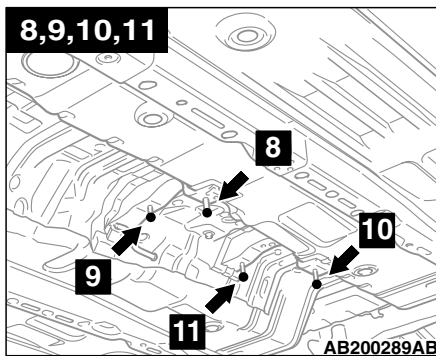
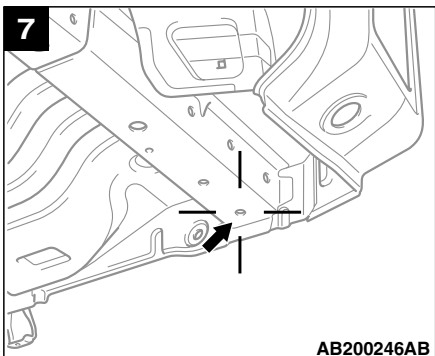
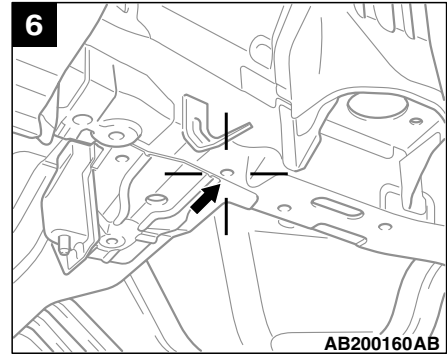
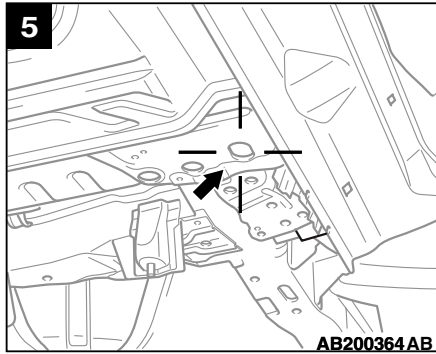
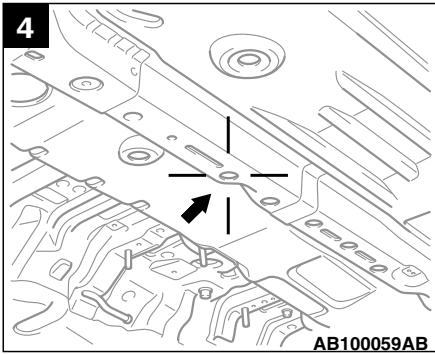
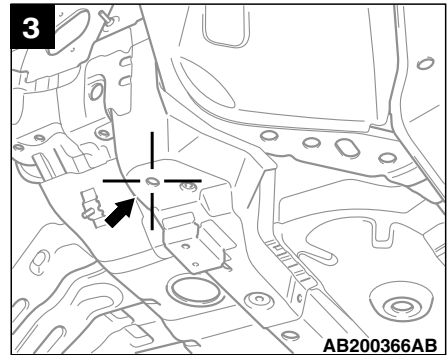
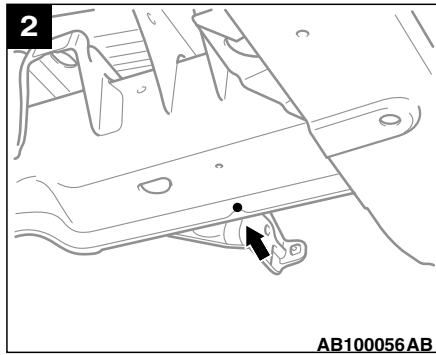
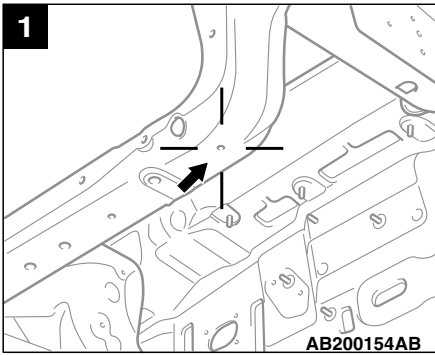

CLICK HERE TO **DOWNLOAD** THE COMPLETE MANUAL

- Thank you very much for reading the preview of the manual.
- You can download the complete manual from: www.heydownloads.com by clicking the link below



- Please note: If there is no response to CLICKING the link, please download this PDF first and then click on it.

CLICK HERE TO **DOWNLOAD** THE COMPLETE MANUAL

BODY DIMENSIONS
TYPE B (ACTUAL-MEASUREMENT DIMENSIONS)

No.	Standard measurement point	Hole shape-Size mm
57	Centre of rear floor crossmember positioning hole (Body centre point)	Round-16
58	Centre of rear shock absorber mounting hole	Round-12
59	Centre of rear end trim mounting hole	Round-8.5
60	Tip of instrument panel bracket center (Body centre point)	-

No.	Standard measurement point	Hole shape-Size mm
61	Centre of deck crossmember mounting hole (left-upper)	Round-11
62	Centre of deck crossmember mounting hole (right-upper)	Round-11
63	Centre of deck crossmember mounting hole (left-lower)	Round-11
64	Centre of deck crossmember mounting hole (right-lower)	Round-11

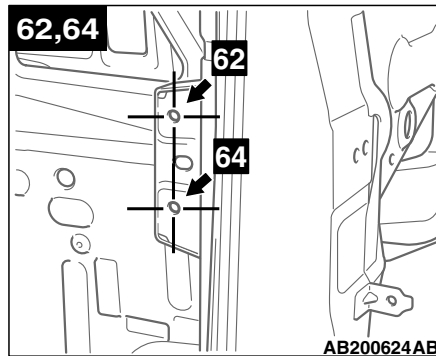
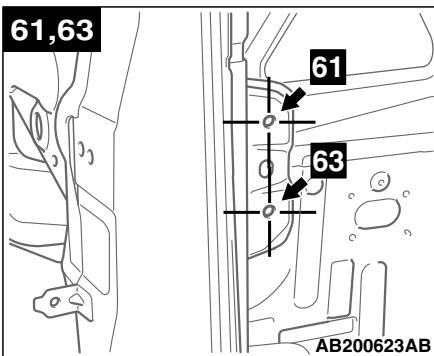
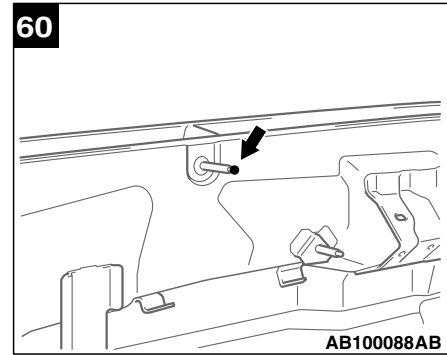
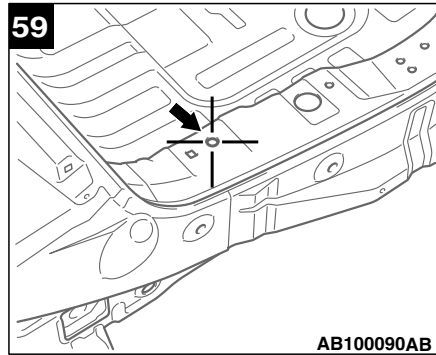
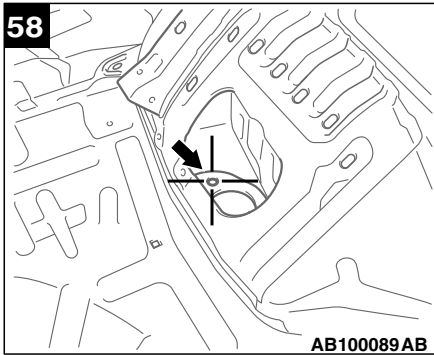

NOTE ON REPAIR WORK

REMOVAL

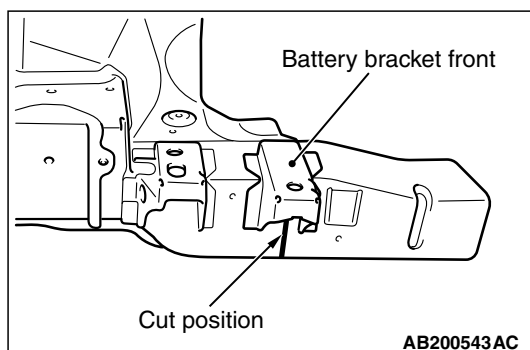

1. Remove the battery bracket front on the cut area in advance when cutting the front sidemember inner.

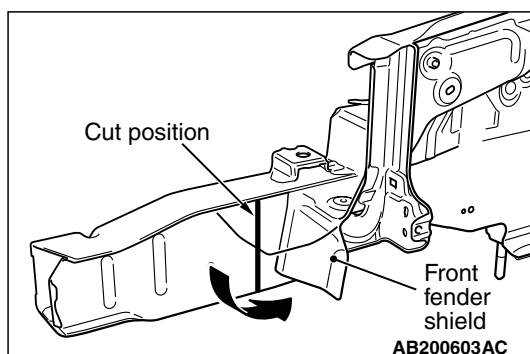

2. As shown in the figure of the instructions, bend the front fender shield on the cut area in advance, when cutting the front sidemember outer.

INSTALLATION

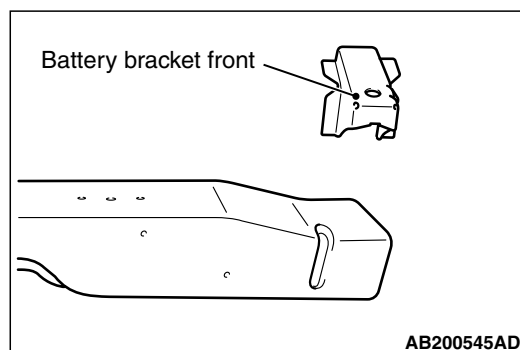

1. Remove the battery bracket front from the new front sidemember inner.

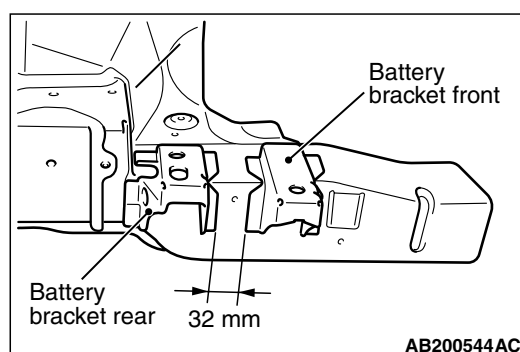

2. Assemble the front sidemember, then assemble the battery bracket front in the location of the figure of the instructions, then return the front fender shield bent back to the original state.

NOTE ON REPAIR WORK

REMOVAL

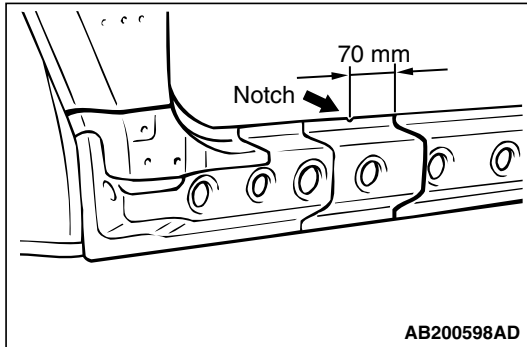

To remove the side sill outer reinforcement, cut it 70 mm behind the notch.

INSTALLATION

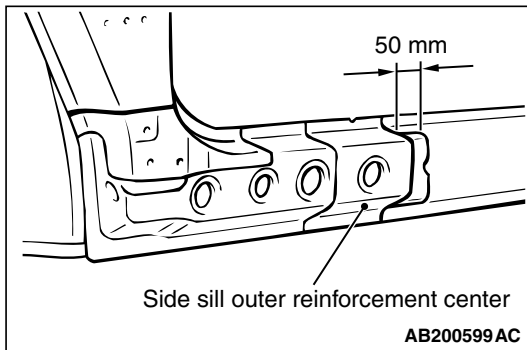

1. Cut only the side sill outer reinforcement center on the body-side, 50 mm forward of the cut area and then remove.

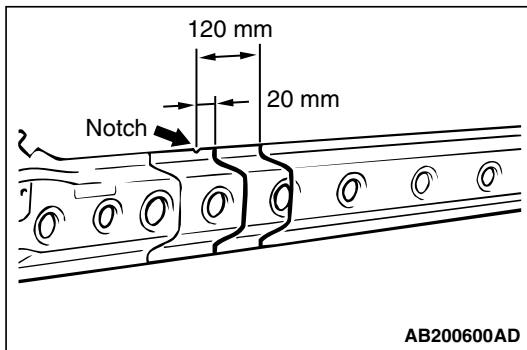

2. Cut only the side sill outer reinforcement center of the new side sill outer reinforcement parts from 120 mm behind the notch, then cut from another 20 mm behind the notch and remove. Re-use the parts removed.

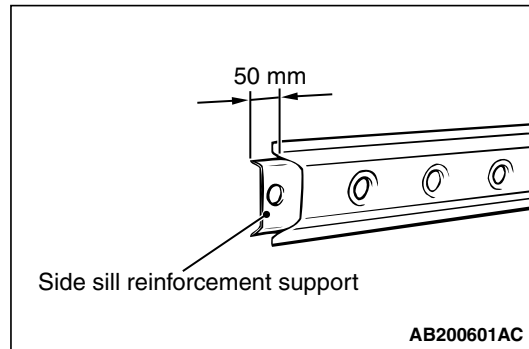

3. Cut the side sill reinforcement support 50 mm forward of the cut area of the side sill outer reinforcement center.

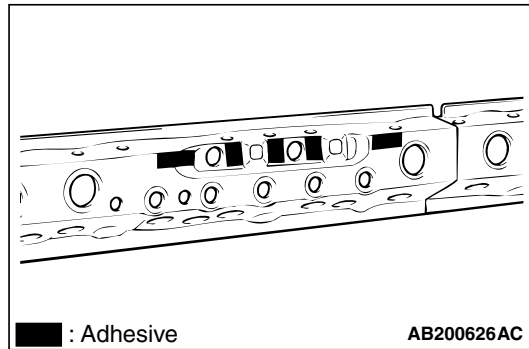

4. Adhere in advance adhesives in the areas shown in the figure of the instructions when assembling the side sill outer reinforcement.

Adhesive	Type	Brand
	Epoxyayresin adhesive	3M™ Part No.8115 or equivalent

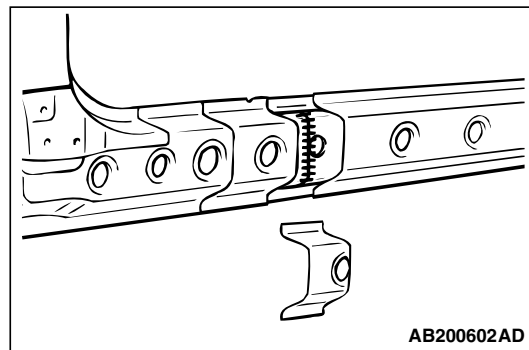

5. After assembling the new parts to the body, weld the side sill reinforcement support, then weld the part cut from the side sill outer reinforcement center.

QUARTER, INNER

M4030012000120

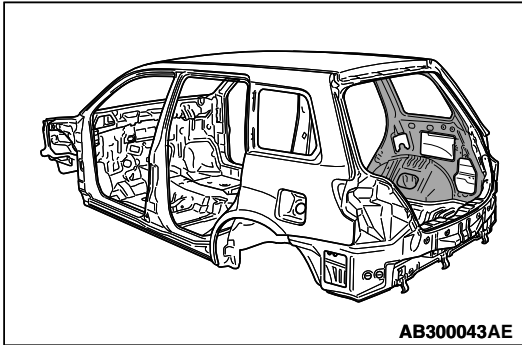

Symbol	Operation description
● ● ● ●	Spot welding
■ ■ ▲ ▲	MIG plug welding (■ : indicates two panels to be welded ▲ : indicates three panels to be welded)
++++	MIG spot welding
#####	MIG arc welding (continuous)
○○○○○○	Braze welding
	Anti-corrosion agent application locations (Use access holes to apply liberally to butt-welded joints.)

REPAIR WELDS

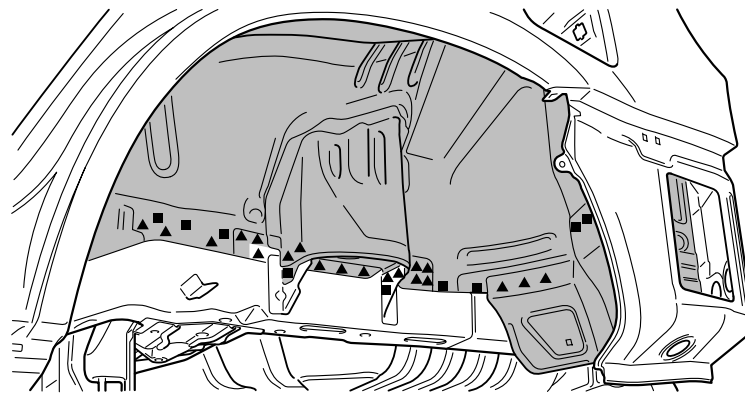
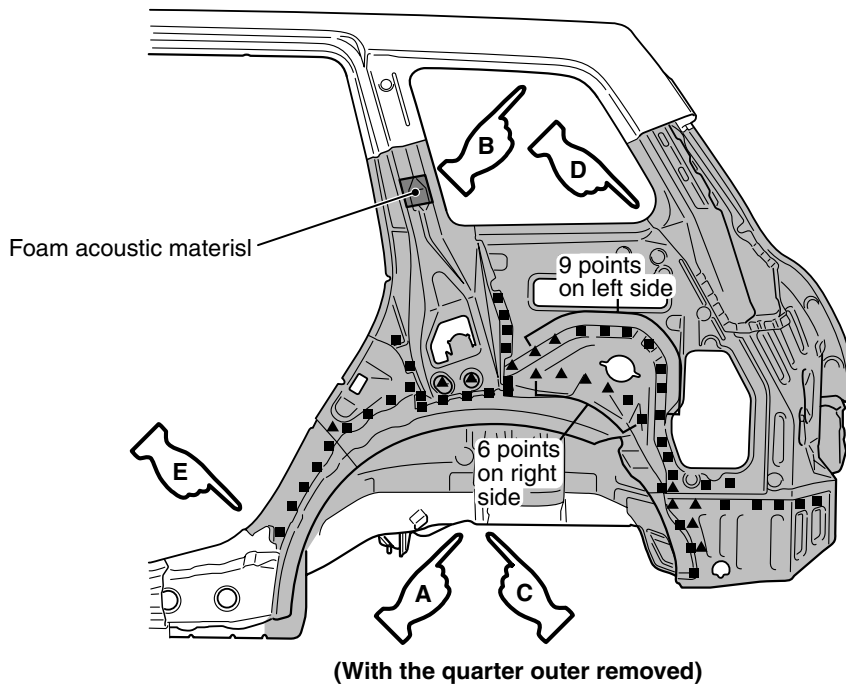

AB300141AB

A

CAUTION

When repairing the area using foam materials do not use firing tools since the foaming materials may burn.

NOTE: Refer to the Quarter Outer Section on P.3-21 for the welding points with the quarter outer.

Application surfaces

← : Nozzle insertion openings

2

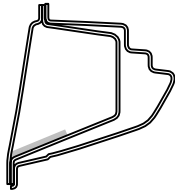

AB202243

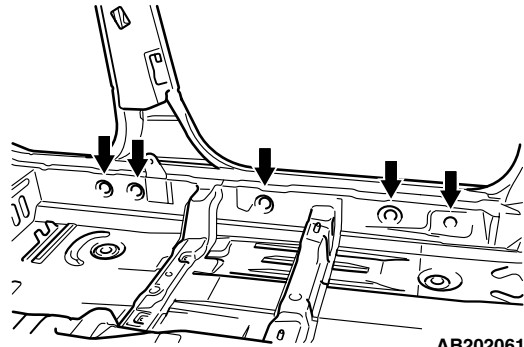

AB202061AB

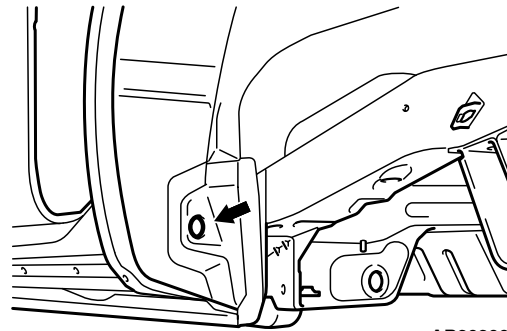

AB202060AB

3

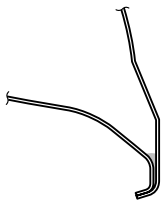

AB300165

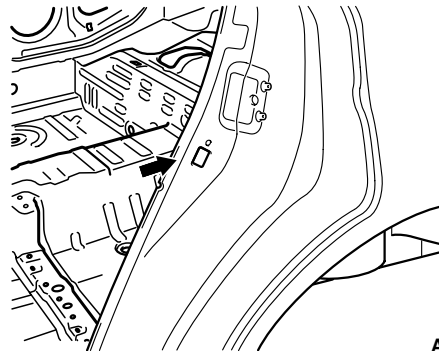

AB202066AB

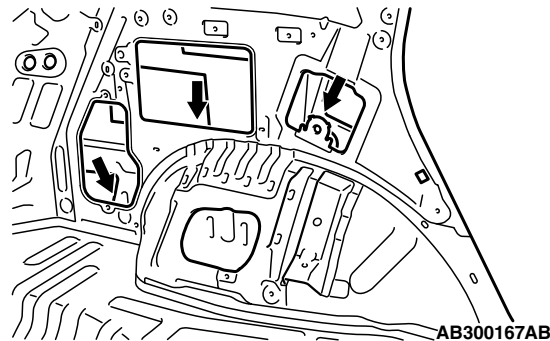

AB300167AB

BODY COLOURING

BUMPER

M4060008000078

Front bumper

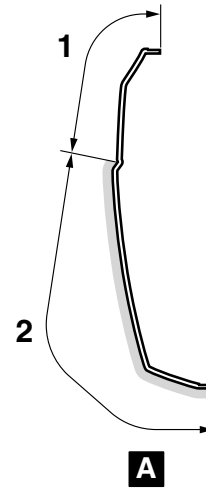
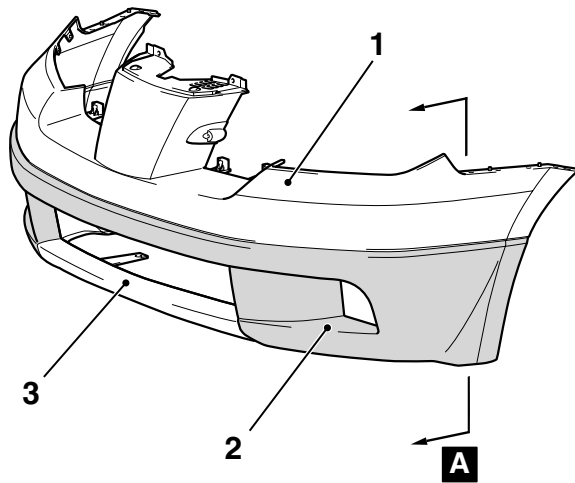

AB200478 AC

Rear bumper

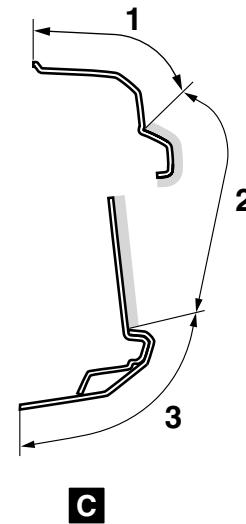
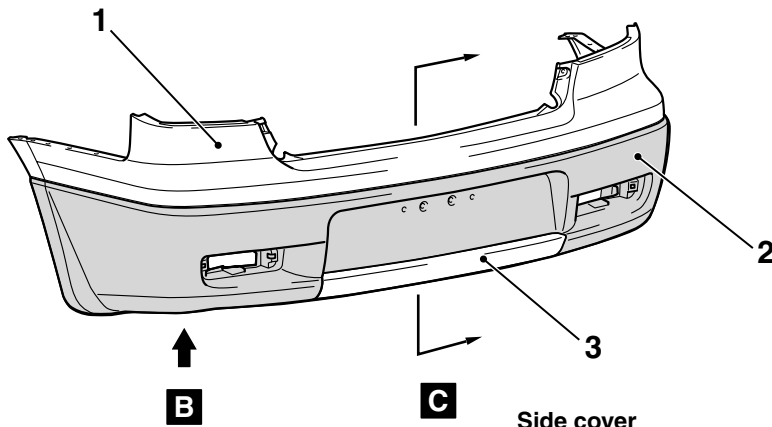

Side cover

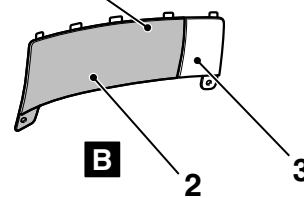

1	Body colour
2	CMH18015 (Medium Argent)
3	AC11169 (Silver)

AB300107AC

CLICK HERE TO **DOWNLOAD** THE COMPLETE MANUAL

- Thank you very much for reading the preview of the manual.
- You can download the complete manual from: www.heydownloads.com by clicking the link below



- Please note: If there is no response to CLICKING the link, please download this PDF first and then click on it.

CLICK HERE TO **DOWNLOAD** THE COMPLETE MANUAL