



DISCOVERY
ACCESSORIES



GB

WARNING

Accessories which are not properly fitted can be dangerous. Read the instructions carefully prior to fitting. Whilst fitting, comply with the instructions at all times. If in doubt contact your nearest Land Rover Dealer.

F

ATTENTION

Des accessoires non fixés correctement peuvent être dangereux. Lisez attentivement les instructions de montage avant la pose. Bien que cette dernière corresponde aux instructions. En cas de doute, adressez vous à votre concessionnaire Land Rover le plus proche.

E

AVISO

Aquellos accesorios que no hayan sido ajustados debida mente pueden resultar peligrosos. Lea las instrucciones detenidamente antes de iniciar el montaje. Durante el montaje siga las instrucciones en todo momento. En caso de duda póngase en contacto con su Concesionario Land Rover.

I

AVVERTENZA

Gli accessori non sistemati come previsto possono essere pericolosi. Leggere attentamente le istruzioni prima del fissaggio. Durante il montaggio seguire sempre le relative istruzioni. In caso di dubbio rivolgersi al più vicino concessionario della Land Rover.

D

ACHTUNG!

Nicht sachgemäß montiertes Zubehör kann gefährlich sein. Lesen Sie Montageanleitung sorgfältig durch, bevor Sie das Teil montieren. Halten Sie sich bei der Montage an die Anleitung. Bei Unsicherheiten wenden Sie sich bitte an Ihren Land Rover Händler.

P

ADVERTÊNCIA

Os Acessórios que não são montados adequadamente podem ser perigosos. Leia as instruções cuidadosamente antes de montar. Durante a montagem, obedeça as instruções todo o tempo. Se tiver alguma dúvida, contacte o Concessionário Rover mais próximo.

NL

WAARSCHUWING

Accessoires die niet op de juiste wijze zijn gemonteerd kunnen gevaar opleveren. Lees zorgvuldig de instructies alvorens met de montage te beginnen. Houd u tijdens de montage te allen tijde aan de instructies. Neem bij twijfel contact op met de dichtst bijzijnde Land Rover dealer

CLICK HERE TO **DOWNLOAD** THE COMPLETE MANUAL

- Thank you very much for reading the preview of the manual.
- You can download the complete manual from: www.heydownloads.com by clicking the link below



- Please note: If there is no response to CLICKING the link, please download this PDF first and then click on it.

CLICK HERE TO **DOWNLOAD** THE COMPLETE MANUAL

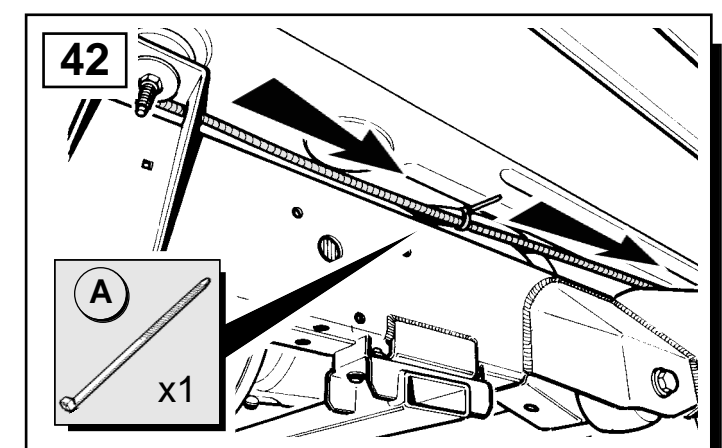
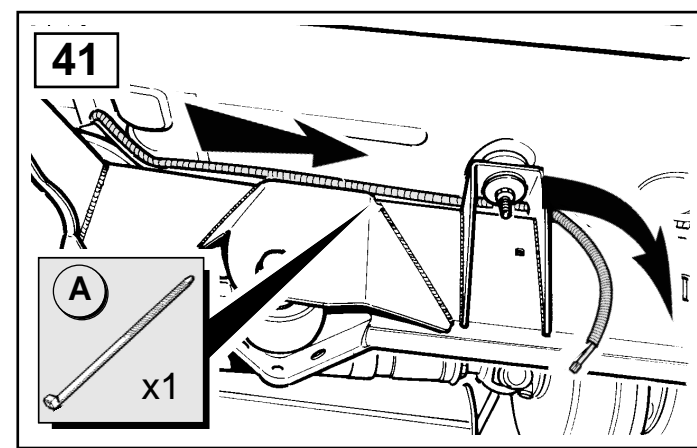
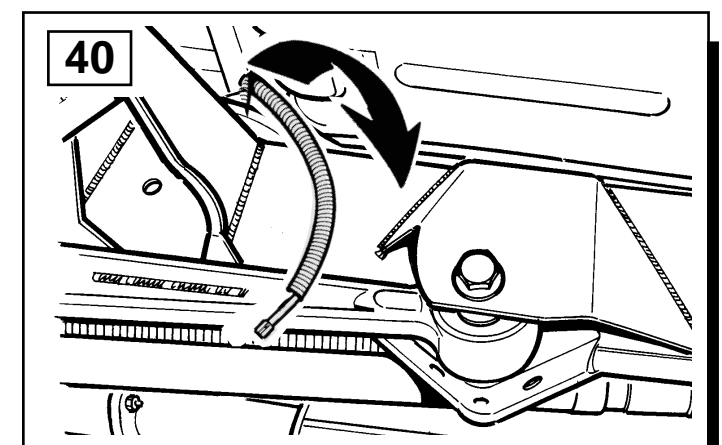
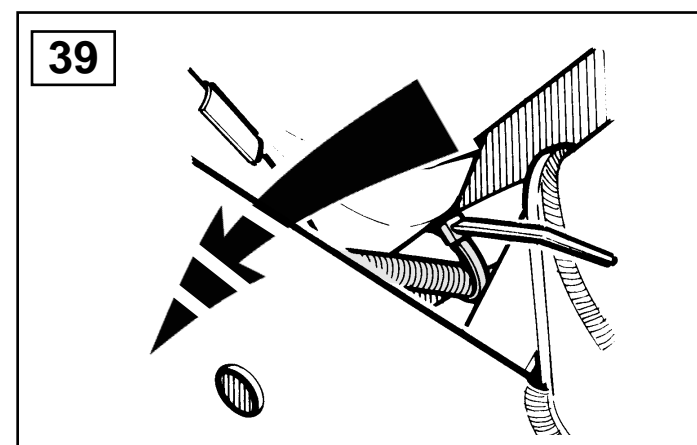
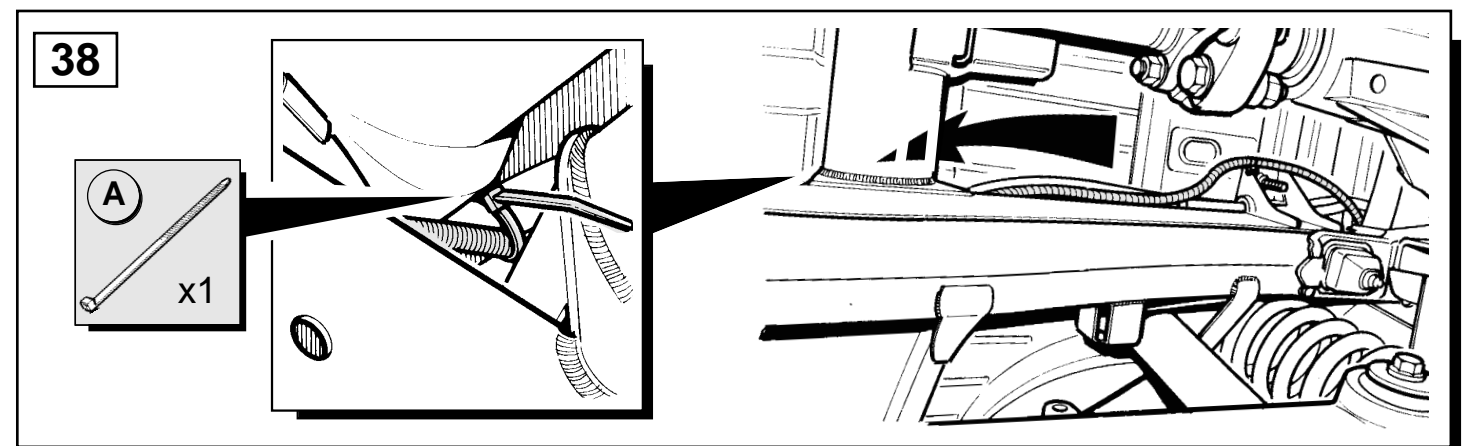
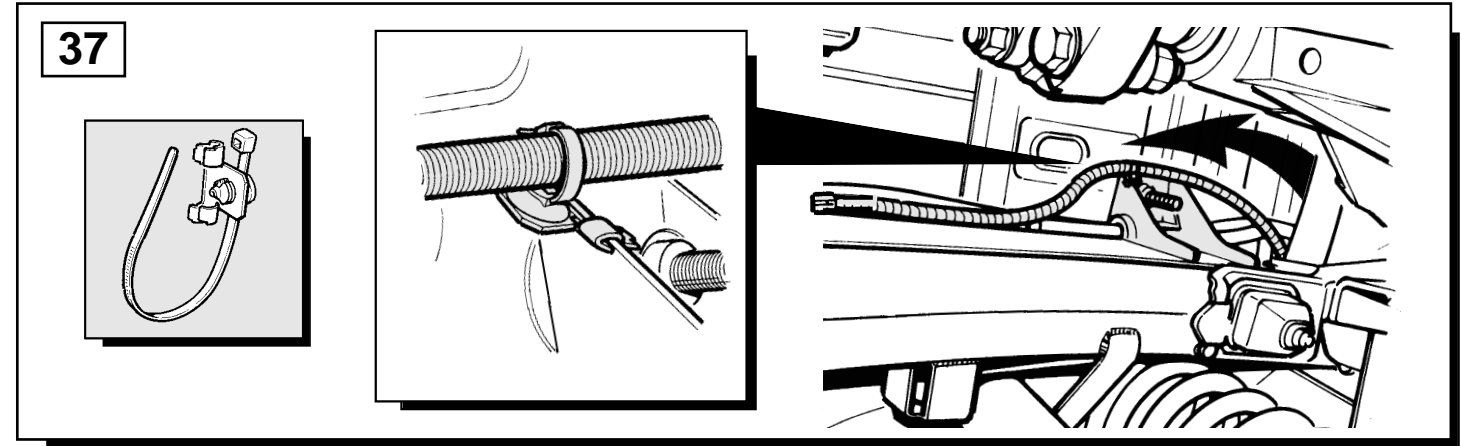
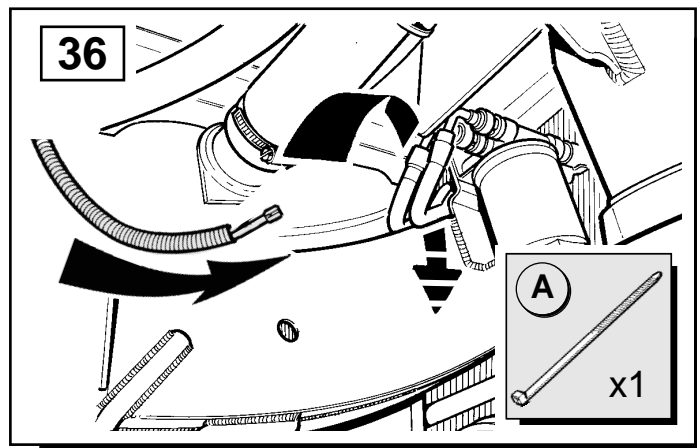
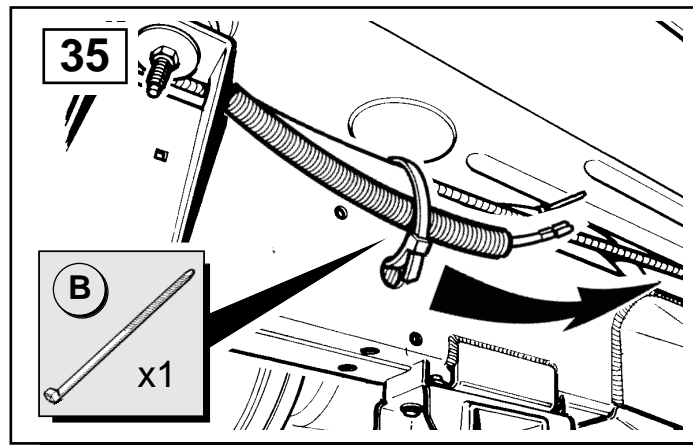
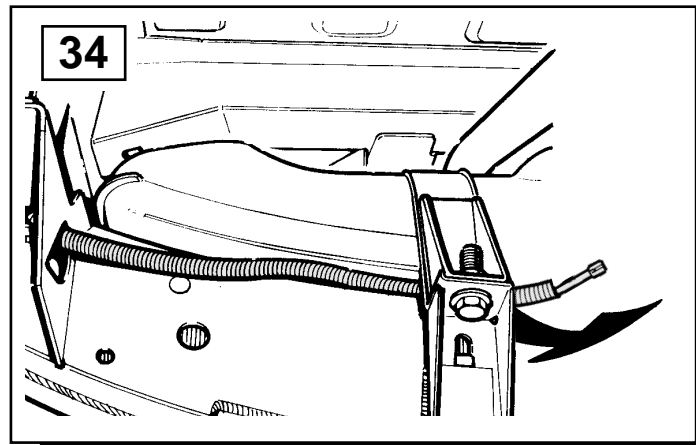
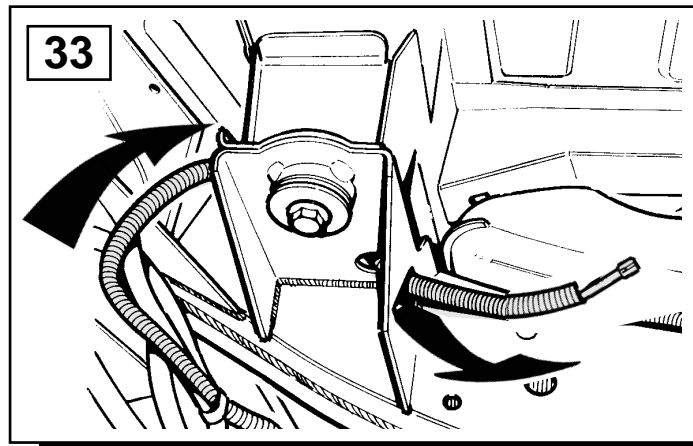
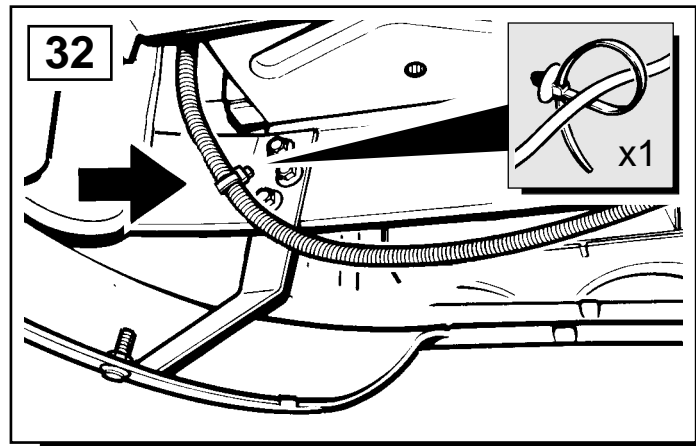
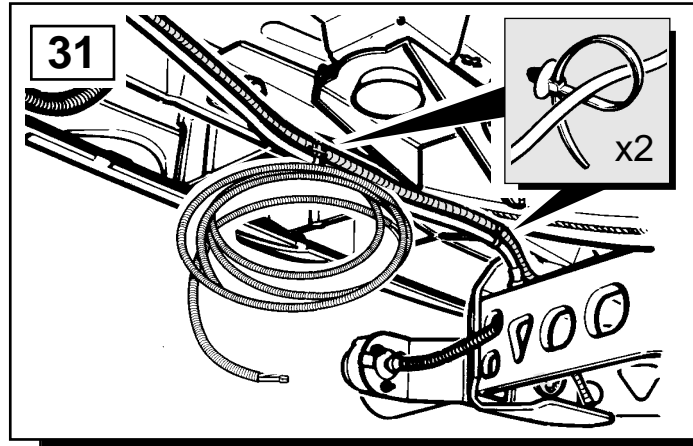
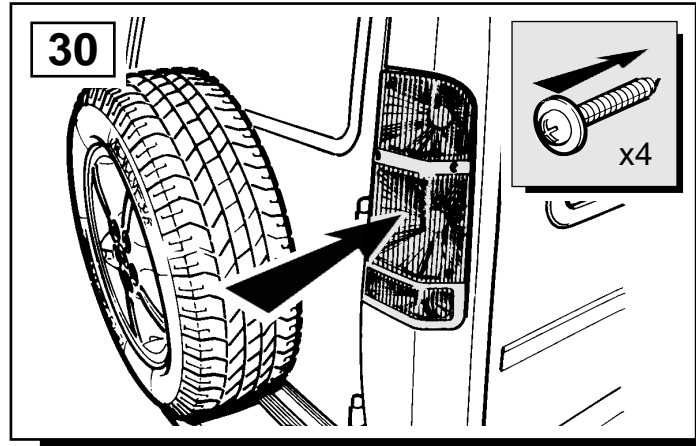

Important Information

This installation manual is in 9 language sections.

ENGLISH Page 5

Wichtige Information

Dieses Installationshandbuch ist in 9 Abschnitte in je einer Sprache unterteilt.

DEUTSCH Page 33

Information importante

Ce manuel d'installation est rédigé en 9 langues.

FRANCAIS Page 61

Informazioni importanti

Questo manuale d'installazione è suddiviso in 9 capitoli, ciascuno in una lingua differente.

ITALIANO Pagina 89

Información importante

Este manual de instalación está dividido en 9 secciones de idiomas.

ESPAÑOL Página 117

Informação Importante

Este manual de instalação está dividido em 9 secções, em função da língua.

PORTUGUÊSPágina 145

Belangrijke informatie

Deze installatiehandleiding is in 9 talen.

NEDERLANDSPagina 173

Σημαντικές Πληροφορίες

Το παρόν χειρίδιο εγκατάστασης περιέχει 9 γλώσσες.

ΕΛΛΗΝΙΚΑΣελίδα 201

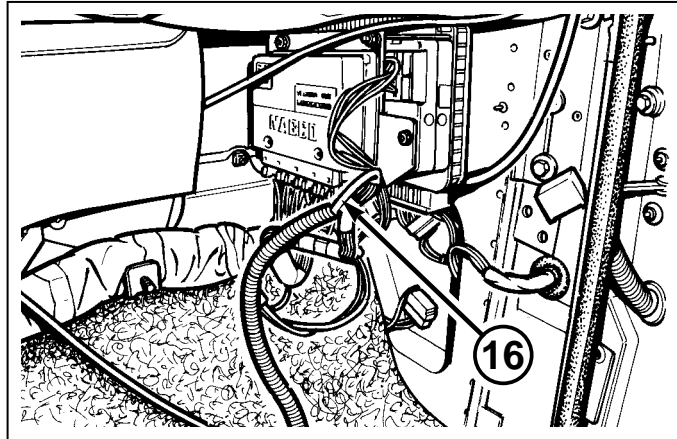

**NEW A/C HARNESS
INTERIOR CONNECTIONS
Continued**

Single Yellow/Slate Wire

- 16 Route the remaining Yellow/Slate to the ECU located in the RH footwell.
- 17 Release and disassemble connector C637 from the ECU.
- 18 Insert the Yellow/Slate wire into cavity 29.
- 19 Reassemble the connector and refit to the ECU.

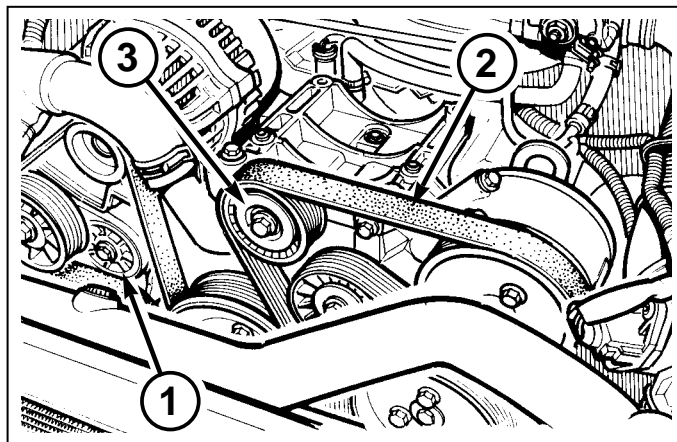
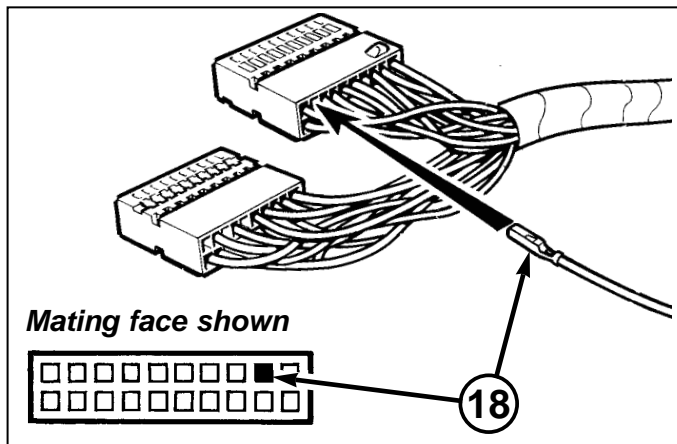
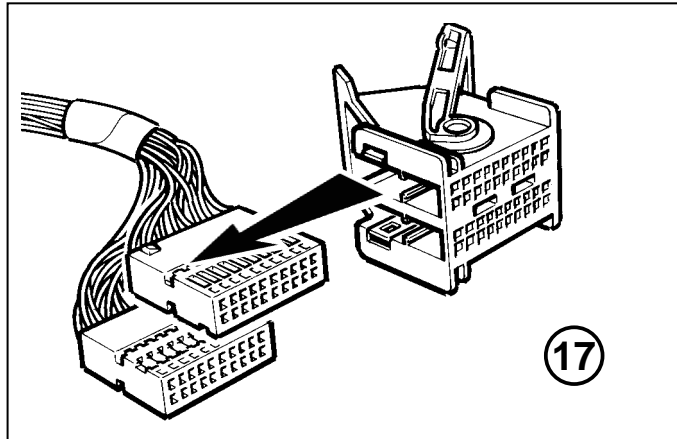

DRIVE BELT

A drive belt tensioner automatically tensions the drive belt eliminating the need for tensioning.

- 1 Release the tension on the drive belt by disengaging tensioner pulley – turn clockwise.
- 2 Remove and discard belt.
- 3 Remove top Idler pulley/mount assembly and discard.

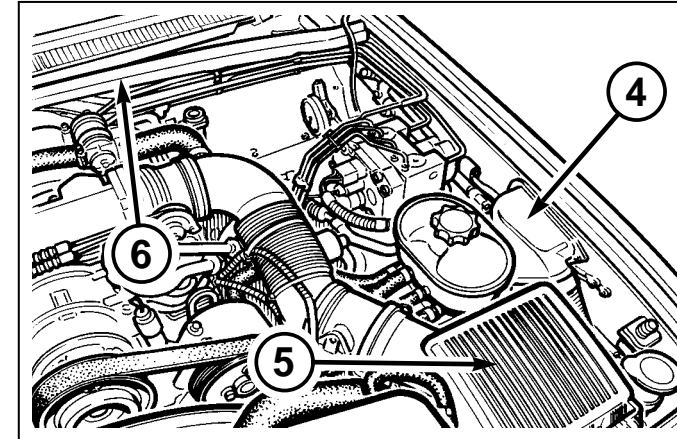

COMPRESSOR

- 4 Disconnect and remove air intake elbow.
- 5 Release Air filter box.
- 6 Release bonnet seal and underbonnet harness from clips.
- 7 Position compressor onto its mount and secure with 4 M8x95mm flange head bolts (supplied in kit). Torque to 25Nm.
- 8 Locate the compressor connector taped back to the vehicle harness and fit to the compressor.
- 9 Release tension on the tensioner pulley and fit new drive belt.

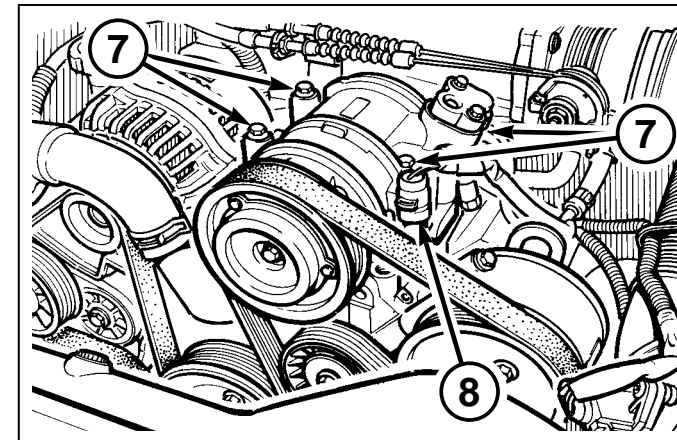

For vehicles with ARC use
Part No. ERR6896
For vehicles without ARC use
Part No. ERR6898

NOTE:
*Ensure the belt is squarely located on pulleys grooves.
No adjustment of the drivebelt should be necessary. If the drive belt is believed to be slack, refer to service manual.*

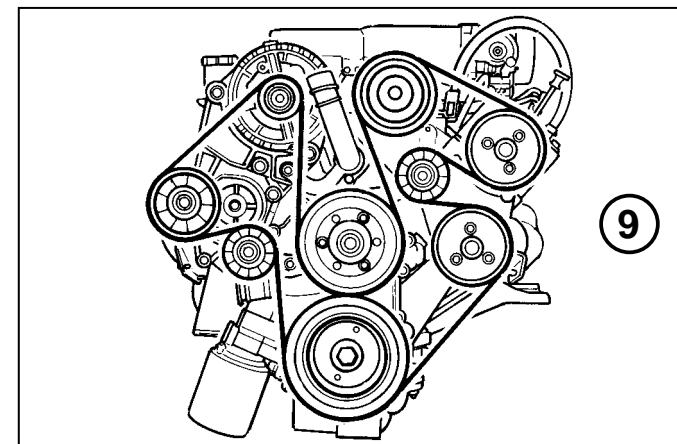

- 10 Refit engine driven fan.

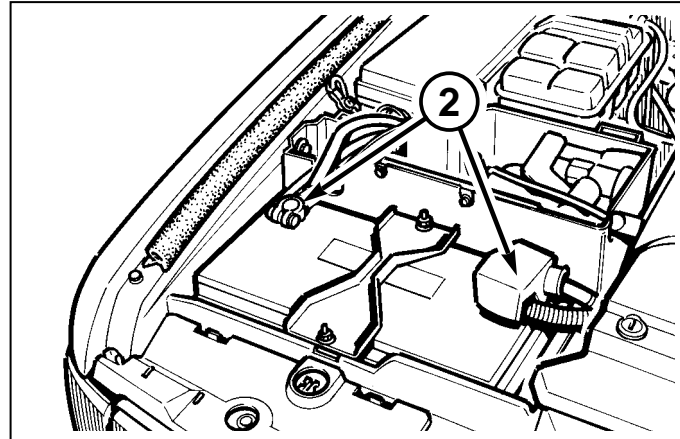

INTERIOR PREPARATION

CENTRE CONSOLE - Removal

- 1 Refer to workshop manual for alarm immobilisation.
Prior to disconnecting the battery note the security code and station settings of the radio.
- 2 Remove battery cover and disconnect the battery cables. (Disconnect the negative cable first).
- 3 Release gaiter and unscrew transfer gear lever knob.

Automatic:

- 4 Lift vertically and disengage gear selector finisher panel from console.
- 5 With a sharp vertical pull, remove gearshift lever and sleeve.

NOTE:

To avoid damage ensure the gear shift lever is pulled vertically.

- 6 Disconnect connector and remove gear selector finisher panel.

Manual:

- 7 Release gaiter from gear lever and pull up over gear knob.
- 8 Remove M8 bolt and remove gear lever.

All Vehicles:

- 9 Remove window switch panel finisher.
- 10 Remove and retain four Phillips screws securing window switch panel.
- 11 It is unnecessary to remove the switch panel. When removing the console pass the switch panel back through its aperture.

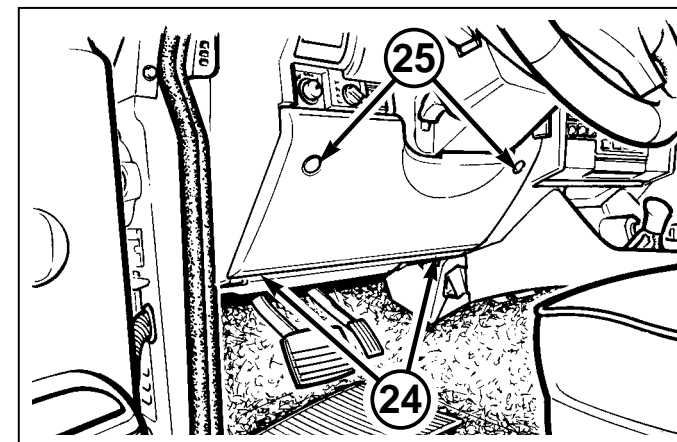
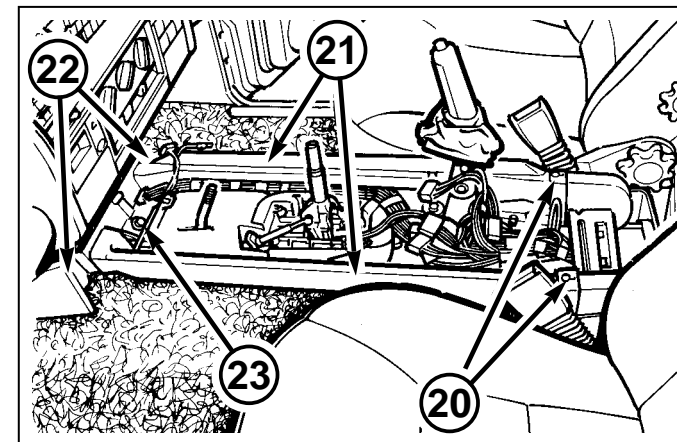
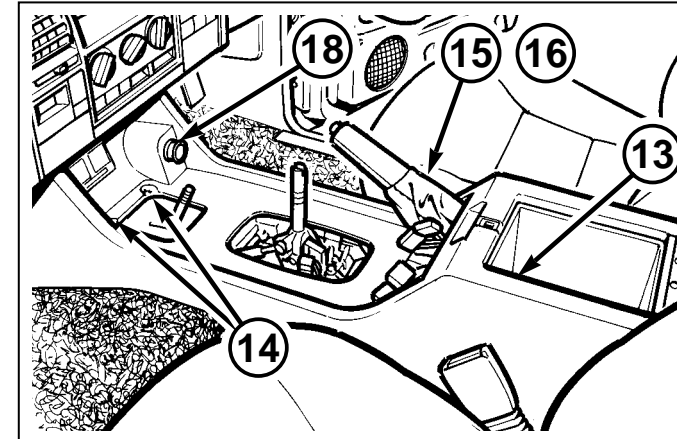
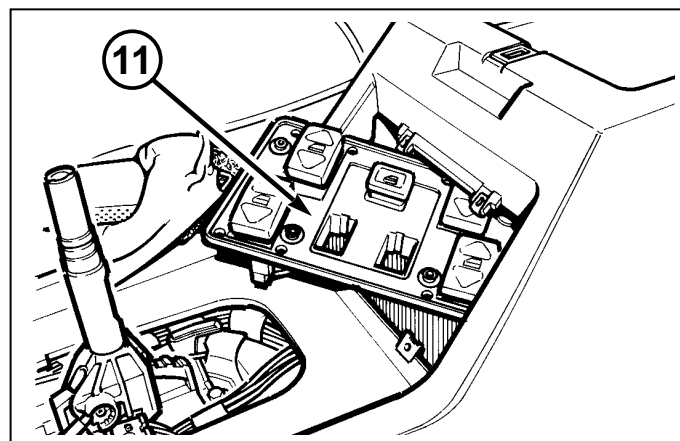
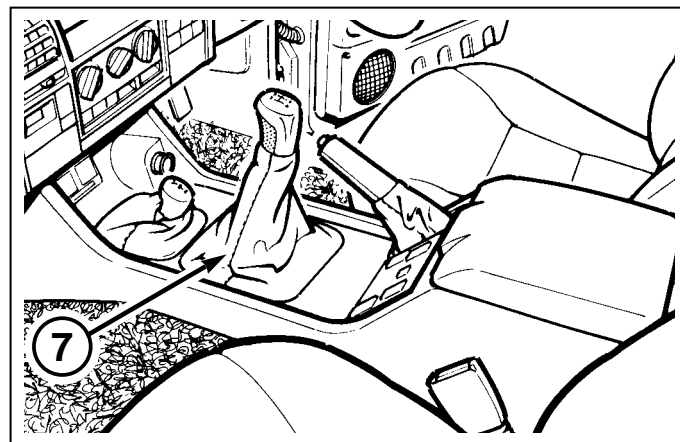
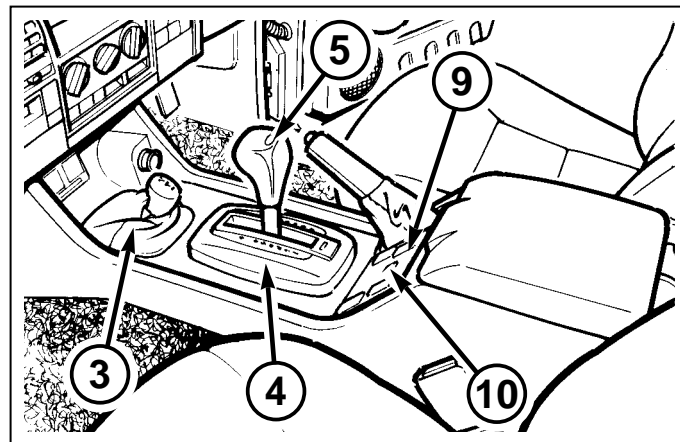

- 12 Remove rubber mat from centre console.
- 13 Open centre console glove box, remove and retain 2 M6 screws.
- 14 Remove and retain the remaining 2 M6 screws at the front of the console.
- 15 Release handbrake gaiter from console.
- 16 Remove the clip and clevis pin securing cable to hand brake.
- 17 Lift handbrake lever to vertical position and manoeuvre console slightly away from tunnel.
- 18 Disconnect Lucar connector and bulb from cigar lighter.
- 19 Lift console assembly over handbrake and gear levers, and remove from vehicle.
- 20 Remove and retain 2 Phillips screws securing rear heater ducts.
- 21 Remove and retain intermediate heater ducts.
- 22 Remove and retain footwell heater ducts and clips.
- 23 Remove and retain 2 Phillips screws securing console mounting bracket in front of transfer lever.
- 24 Remove and retain 4 M5 screws securing drivers closing panel.
- 25 Release turnbuckles and remove drivers closing panel from vehicle.
- 26 Position steering wheel so the road wheels are in the straight ahead position.



SERVICING EQUIPMENT

The following equipment is required for full servicing of the air conditioning system.

Recovery, recycling and charging station.

Leak Detector.

Thermometer +20°C to -60°C

Safety goggles and gloves.

CHARGING

WARNING:

Servicing must only be carried out by an operator familiar with the vehicle system charging procedure and testing equipment. All operations must be carried out in a well-ventilated area away from open flame and heat sources.

CAUTION:

Overcharging air conditioning system will cause excessive head pressure. Refer to workshop manual for correct charging procedure.

REFRIGERANT TO CHARGE SYSTEM IS 700gms

LEAK TEST SYSTEM

The following instructions refer to an electronic type of Refrigerant Leak Detector for use the R134a which are the safest and most sensitive.

- 1 Place the vehicle in a well ventilated area but free from draughts, as leakage from the system could be dissipated without detection.
- 2 Follow the instructions issued by the manufacturer of the particular leak detector being used.
- 3 Commence searching for leaks by passing the detector probe around all joints and components; refrigerant gas is heavier than air.
- 4 Insert the probe into the evaporator drain tube. Switch the heater blower on and off at intervals of ten seconds. Any leakage refrigerant will be gathered in by the blower and detected.
- 5 Insert the probe between the magnetic clutch and compressor to check the shaft seal for leaks.
- 6 Check all TXV valve connections, valve plate, head and base plate joints and back seal plate.
- 7 Check all A/C pipe union connections to all components for leaks ie. condenser, receiver/drier evaporator, compressor.
- 8 If any leaks are found, the system must be discharged before rectification.
- 9 Rectify any leaks and re-check for leaks during evacuation prior to charging.

NOTE:

Check performance of air conditioning.



AIR CONDITIONING SYSTEM - PERFORMANCE TEST

Carry out this test with bonnet and doors or windows open, air conditioning switched on, temperature control set to cold and blower at maximum speed. Set the air supply control to supply fresh air.

- 1 Close low pressure valve on Refrigerant Station.
- 2 Close high pressure valve on Refrigerant Station.
- 3 Connect Refrigerant Station to the high and low pressure servicing connections.
- 4 Insert bulb thermometer into cold air outlet and position dry and wet bulb thermometer close to outside air inlet. Do not spill water from the wet thermometer (psychrometer).

- 5 Start engine and run it at 1500 rev/min for 10 minutes with air conditioning switched on.
- 6 Check that sight glass is free from bubbles.
- 7 Read both pressure gauges and thermometers. Check reading against table below with humidity between 60% and 80%. If readings are incorrect refer to COMPLAINTS DURING TEST in Fault Finding section of the Service Manual.
- 8 Switch off air conditioning, stop engine, disconnect test equipment.

PERFORMANCE RANGE			
Intake Temperature	Outlet Temperature	Low Pressure	High Pressure
20 - 24°C	4 - 10°C	18 - 28 lbf/in ² 1.2 - 1.9 bar	213 - 299 lbf/in ² 14.7 - 20.06 bar
25 - 29°C	9 - 19°C	27 - 37 lbf/in ² 1.9 - 2.6 bar	256 - 341 lbf/in ² 17.6 - 23.5 bar
30 - 35°C	20 - 27°C	33 - 47 lbf/in ² 2.3 - 3.2 bar	299 - 384 lbf/in ² 20.6 - 26.5 bar

Ambient Temperature		Compound Gauge Readings		High Pressure Gauge Readings	
°C	°F	bar	lbf/in ²	bar	lbf/in ²
16	60	1,03 - 1,4	15 - 20	6,9 - 10,3	100 - 150
26,7	80	1,4 - 1,72	20 - 25	9,6 - 13,1	140 - 190
38	100	1,72 - 2,1	25 - 30	12,4 - 15,5	180 - 225
43,5	110	2,1 - 2,4	30 - 35	14,8 - 17,2	215 - 250

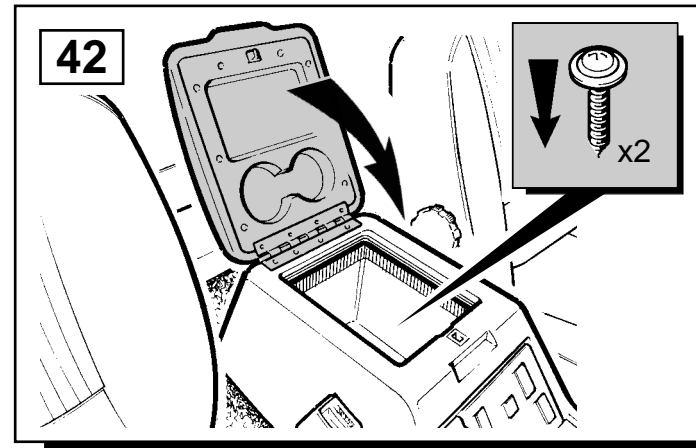
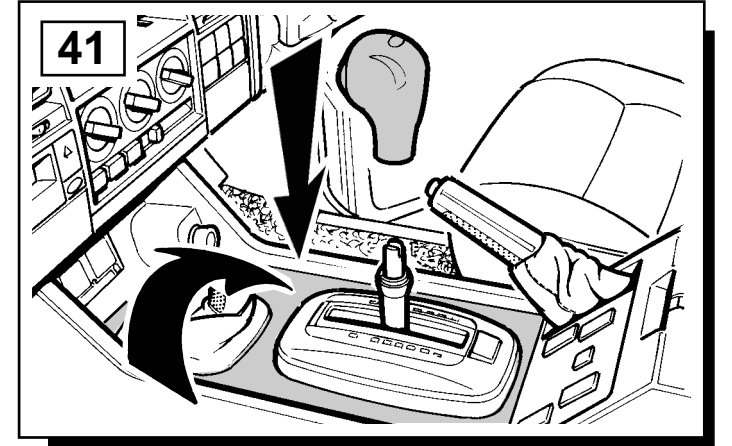
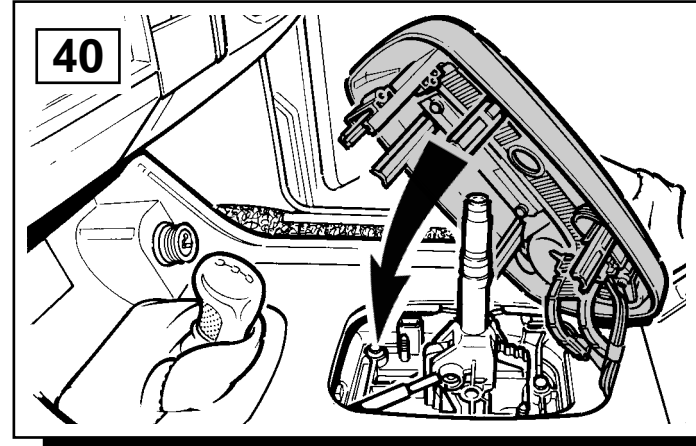
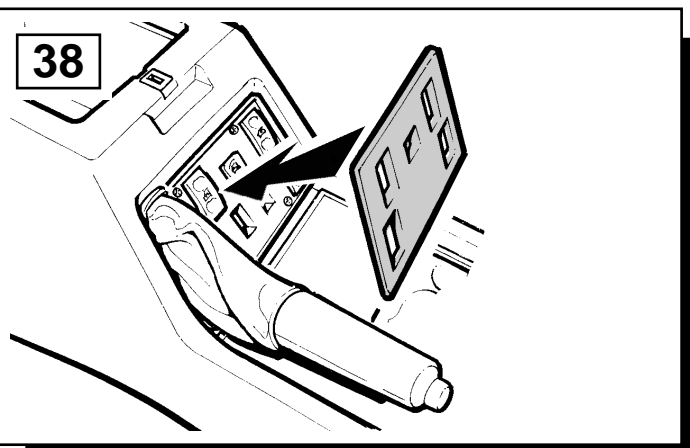
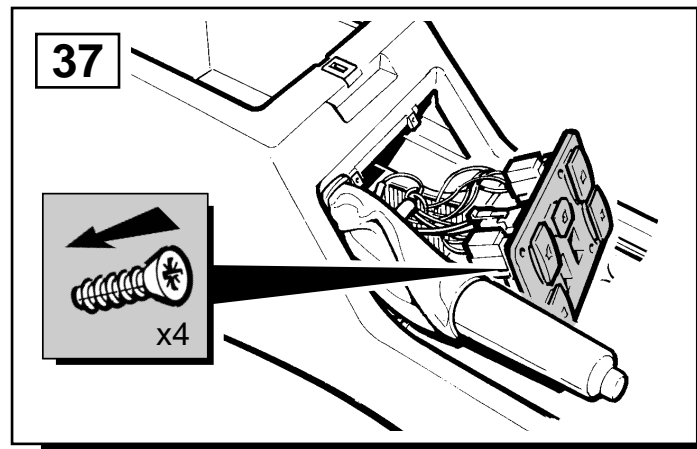
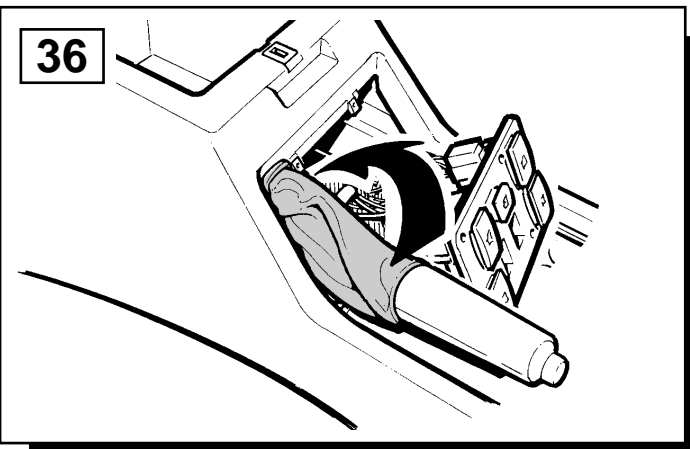
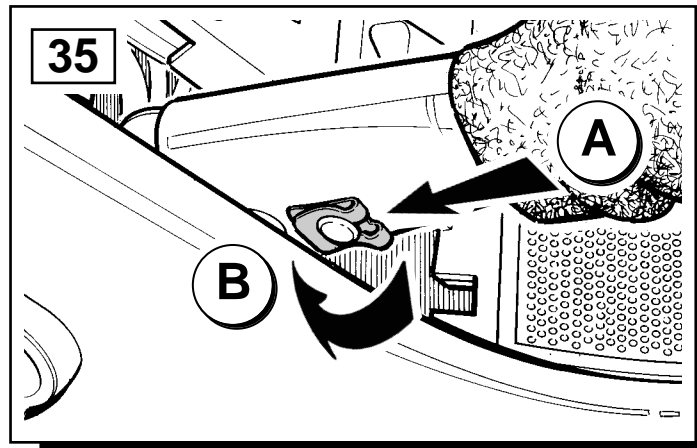
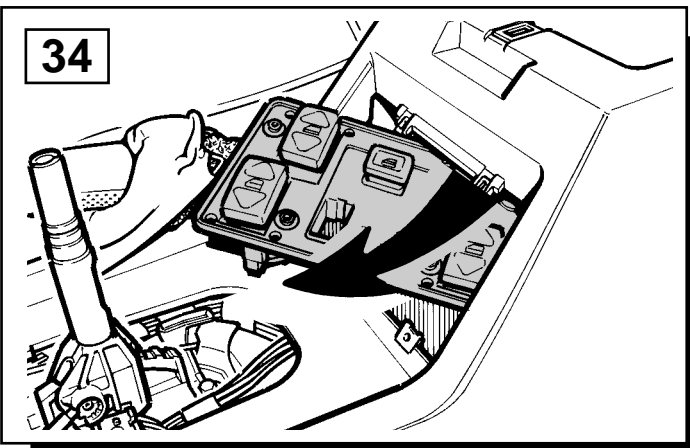
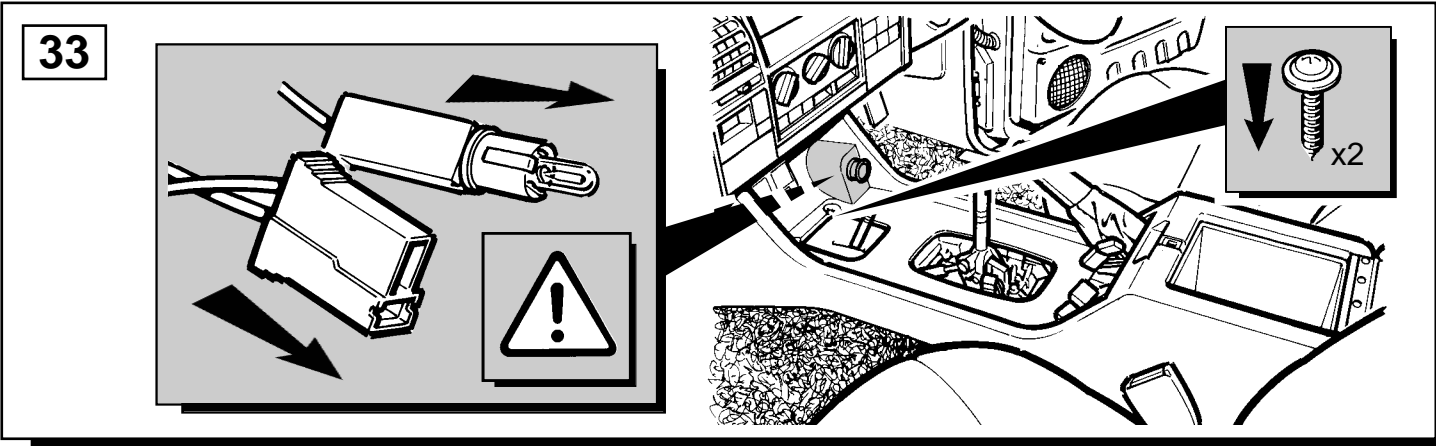

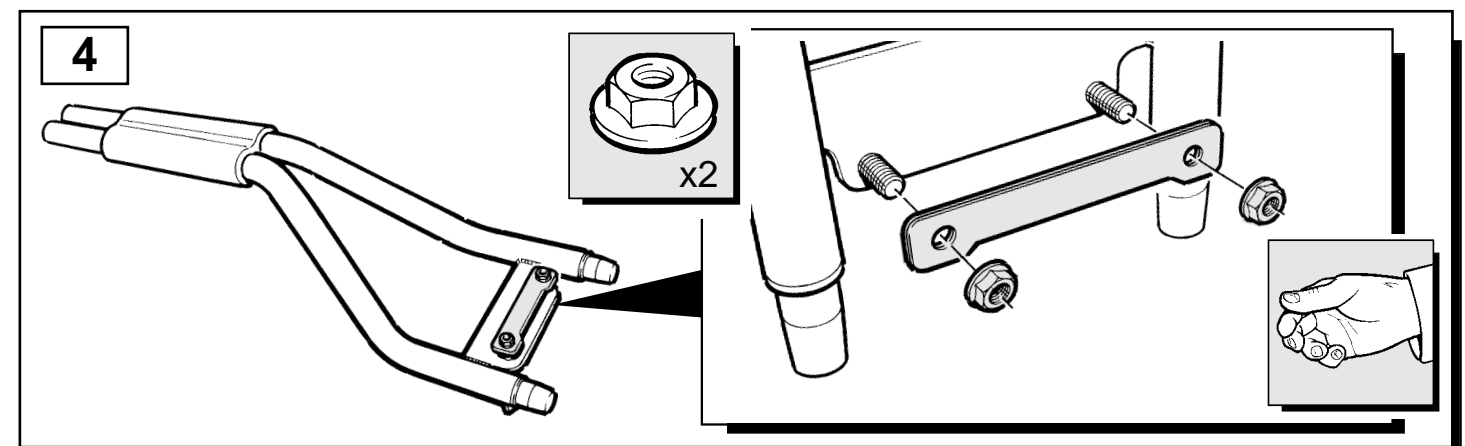
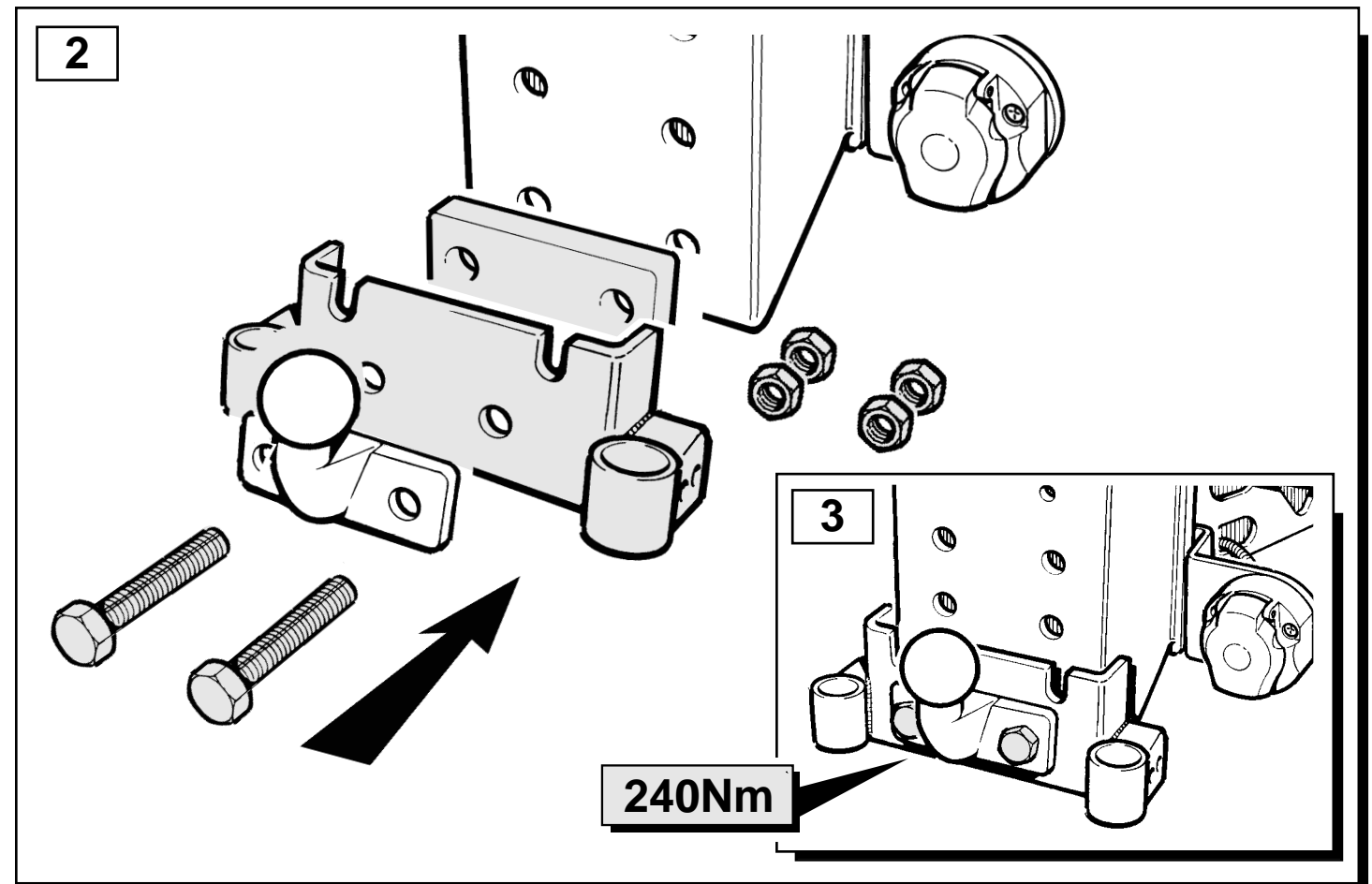
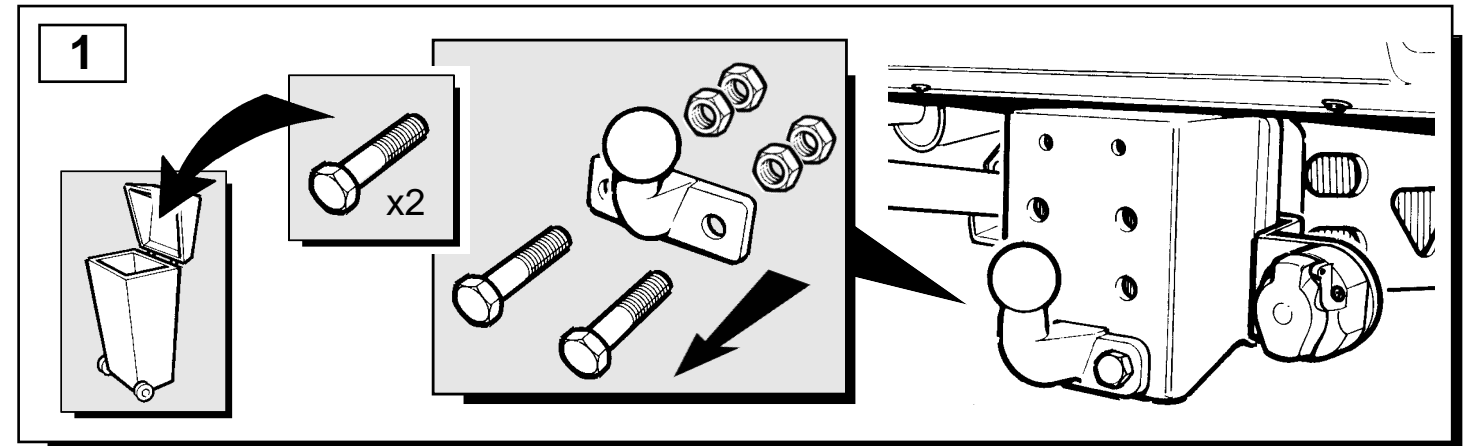
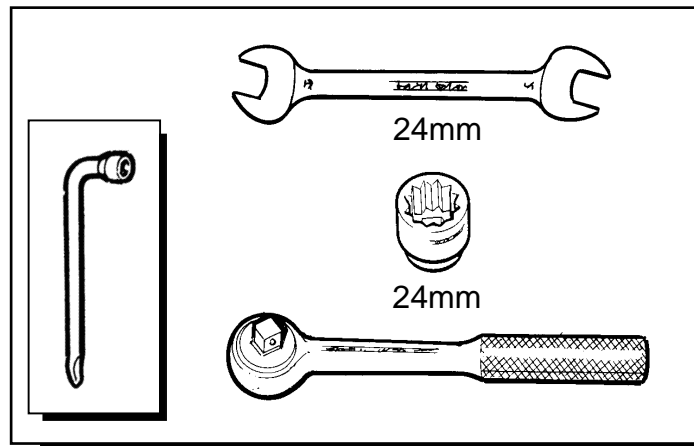
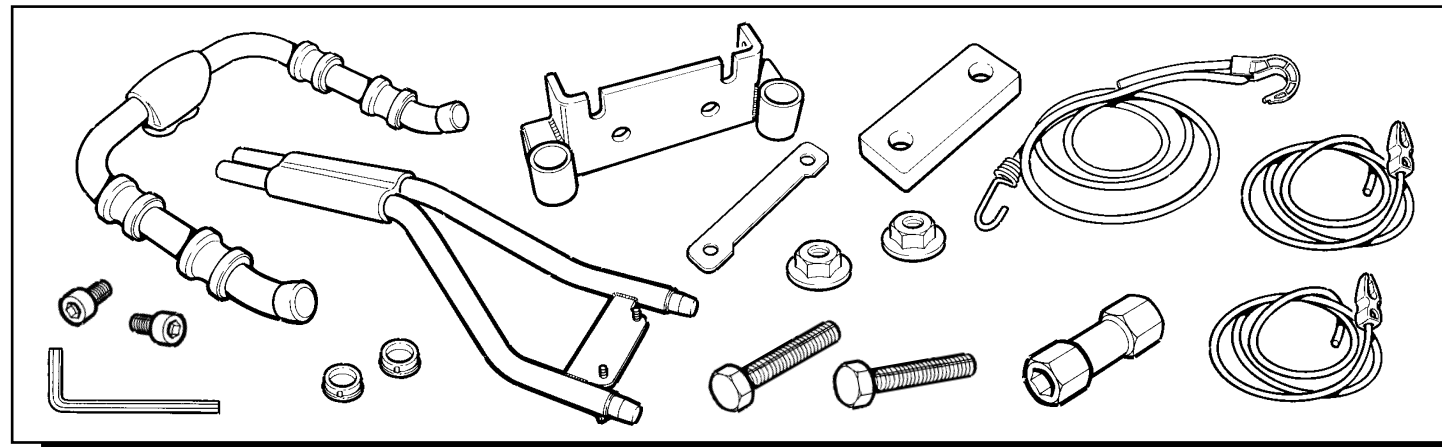
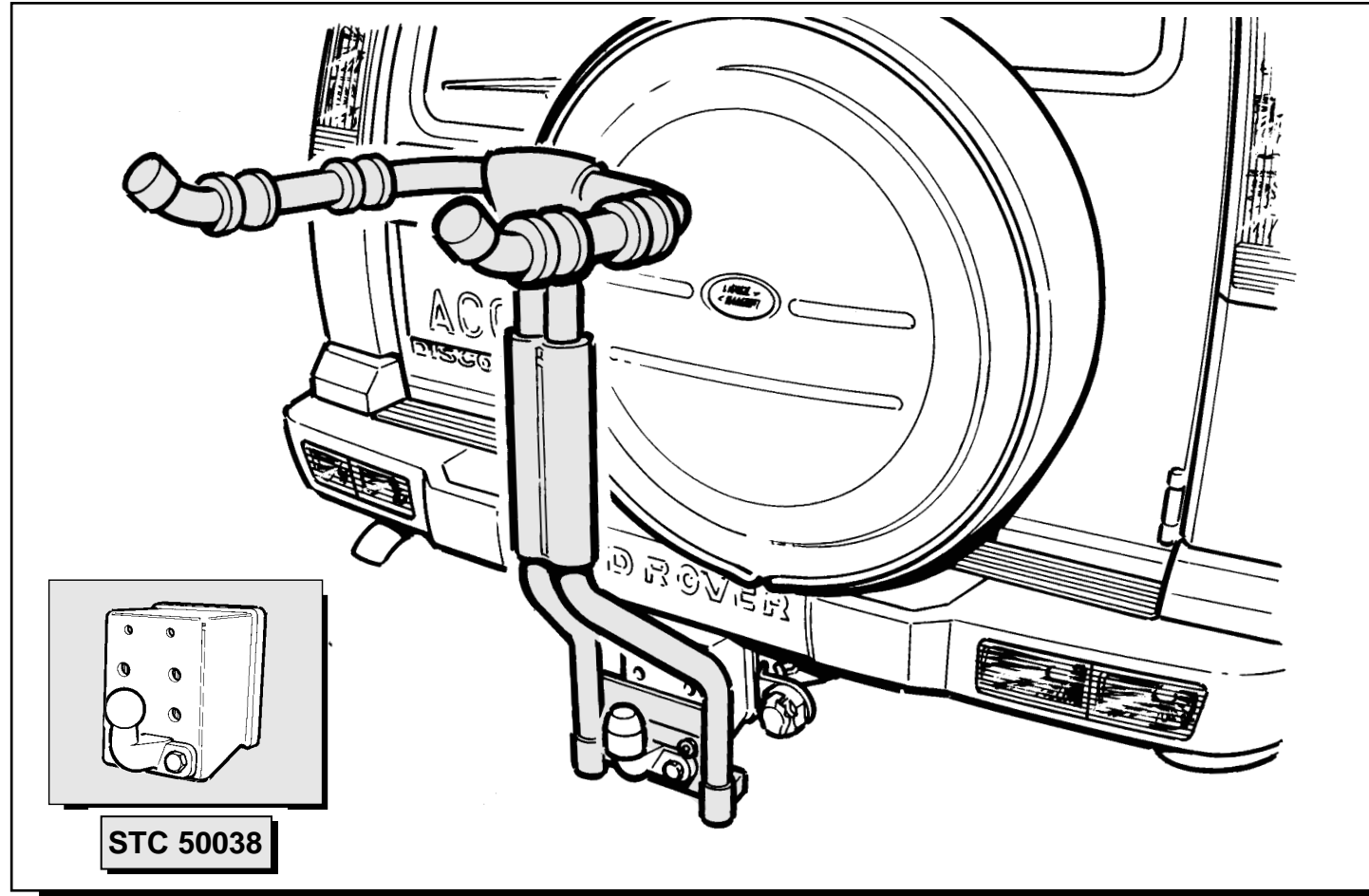

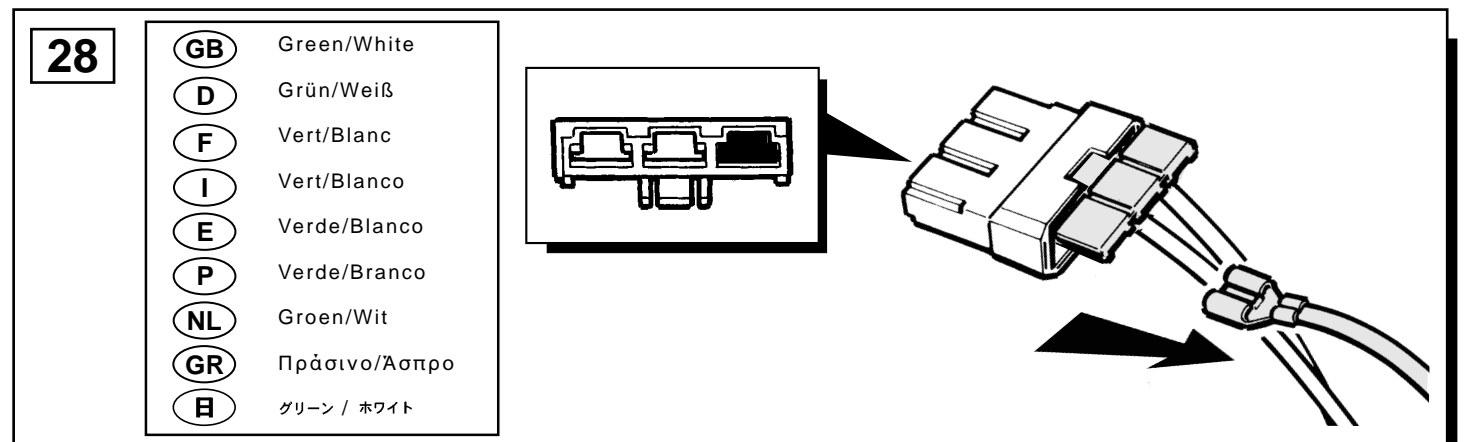
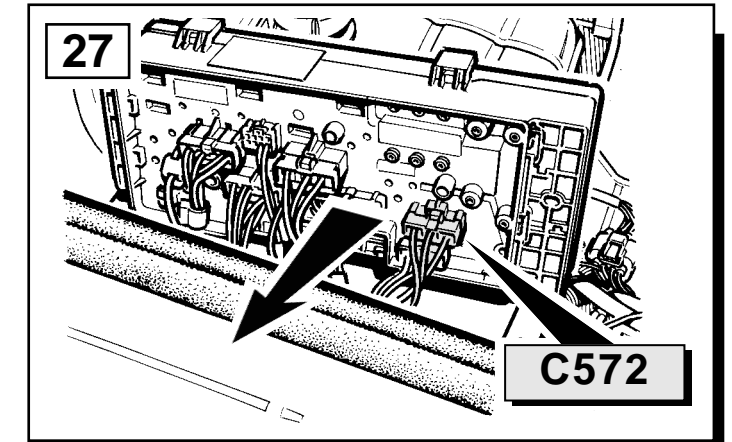
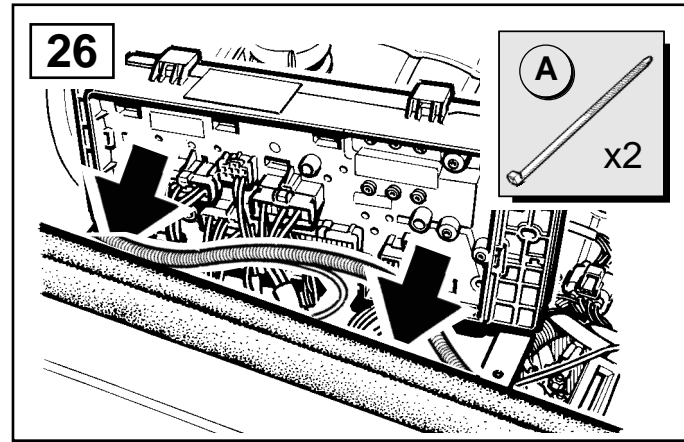
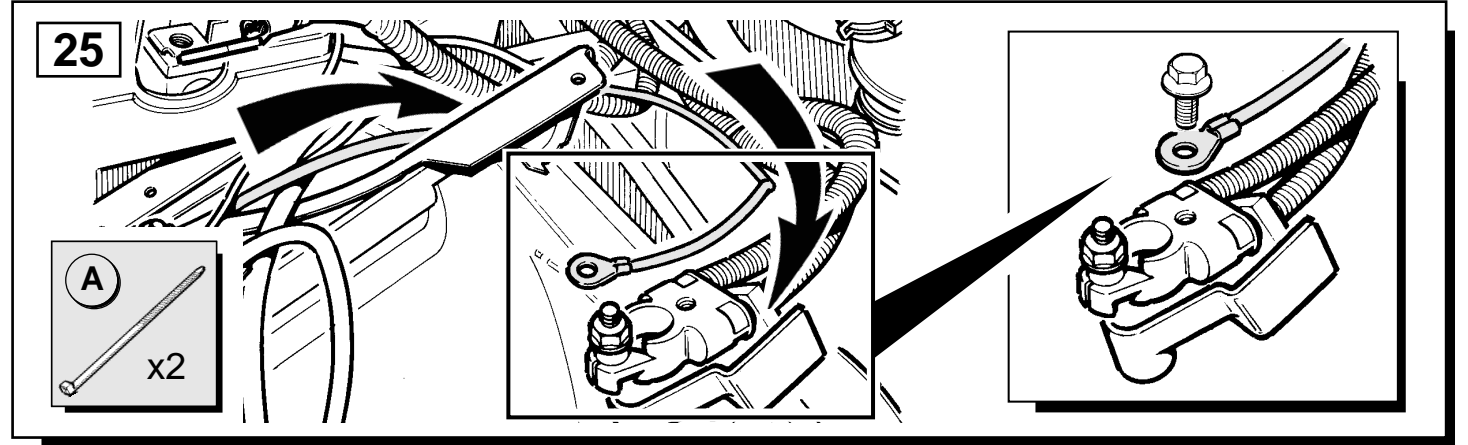
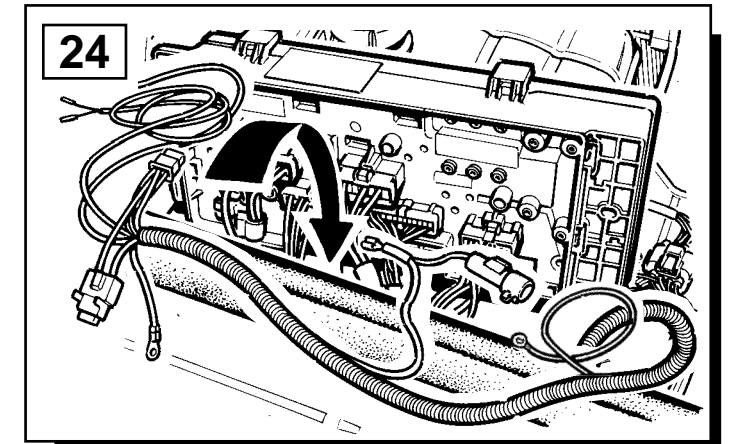
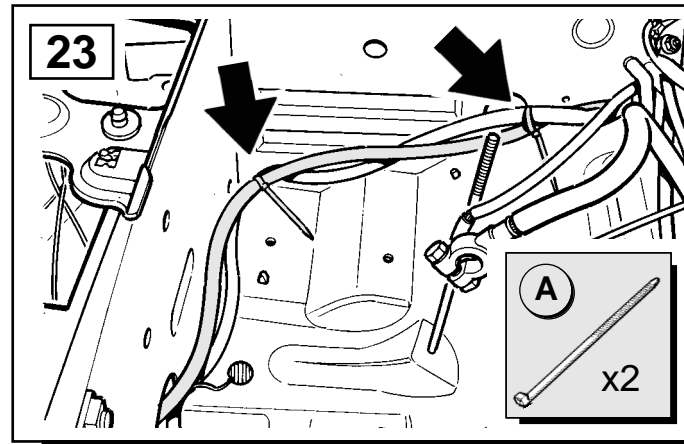
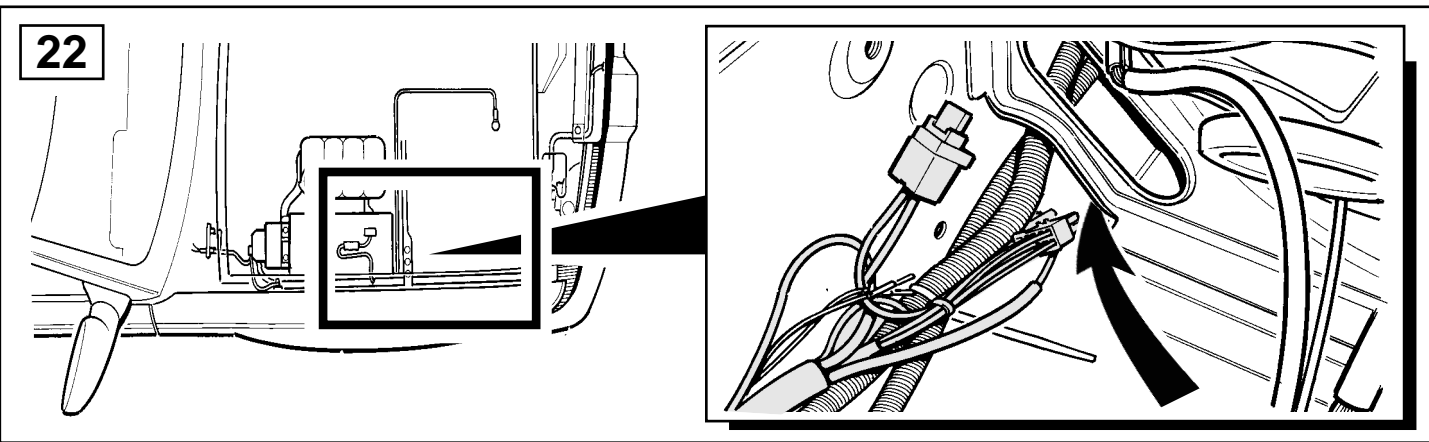
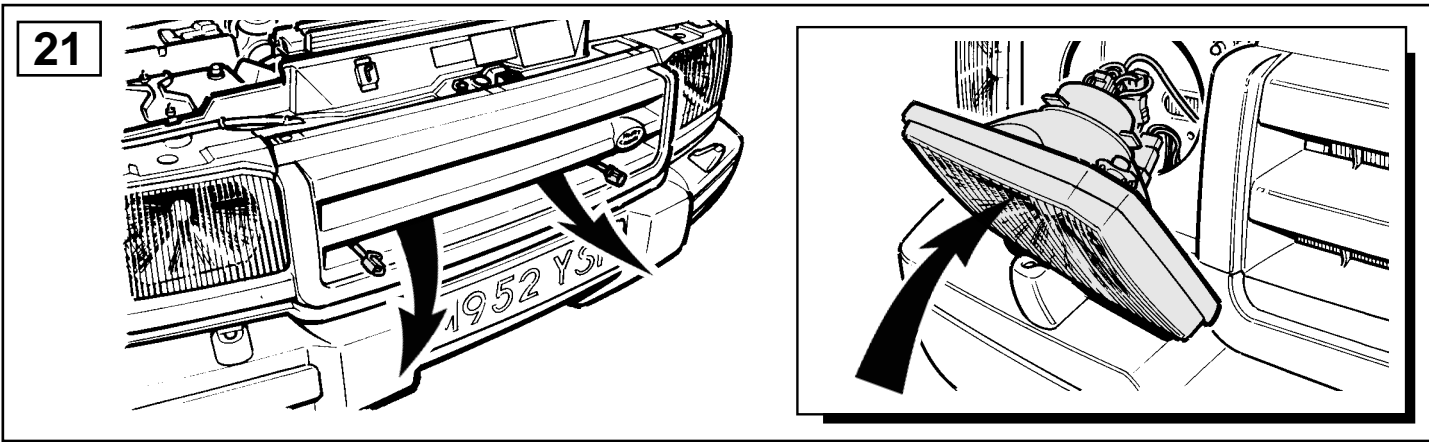
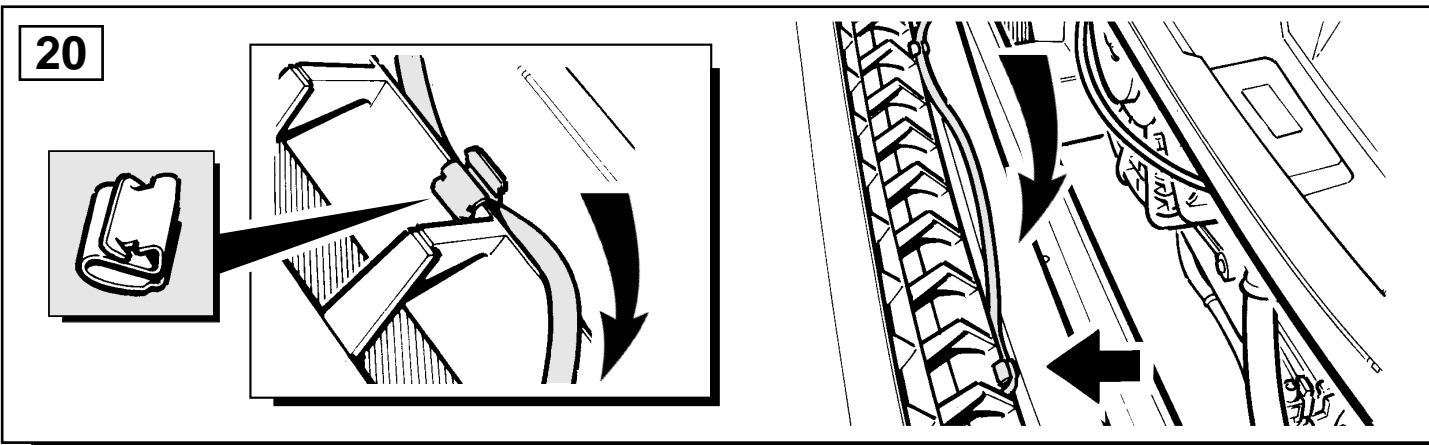
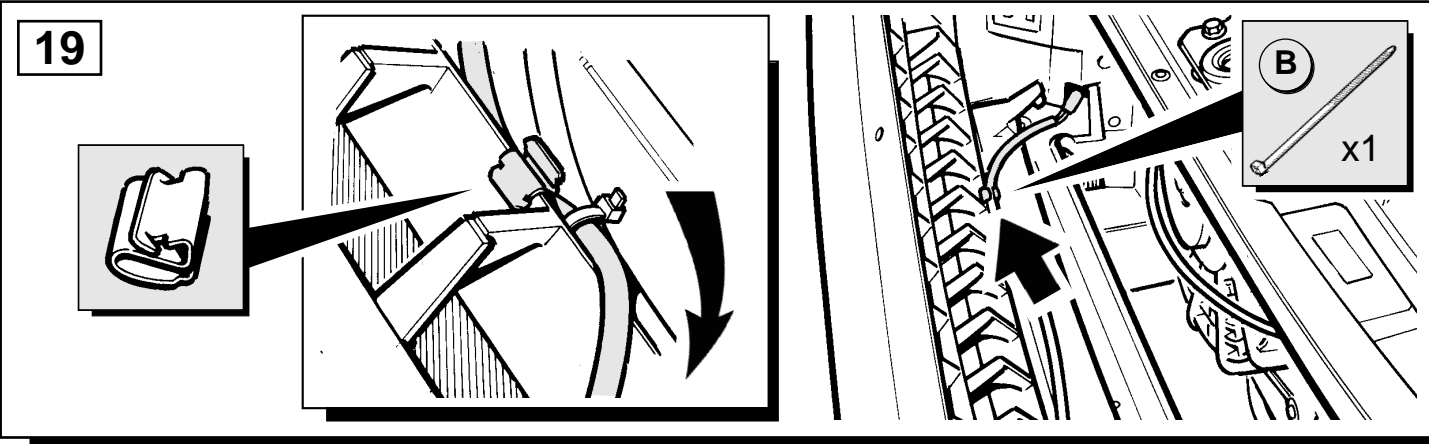

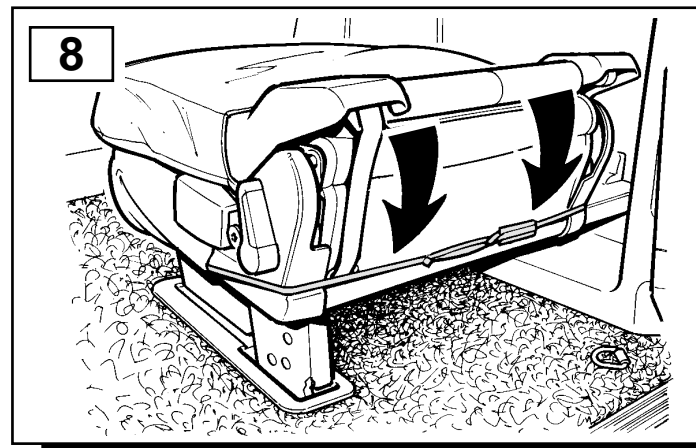
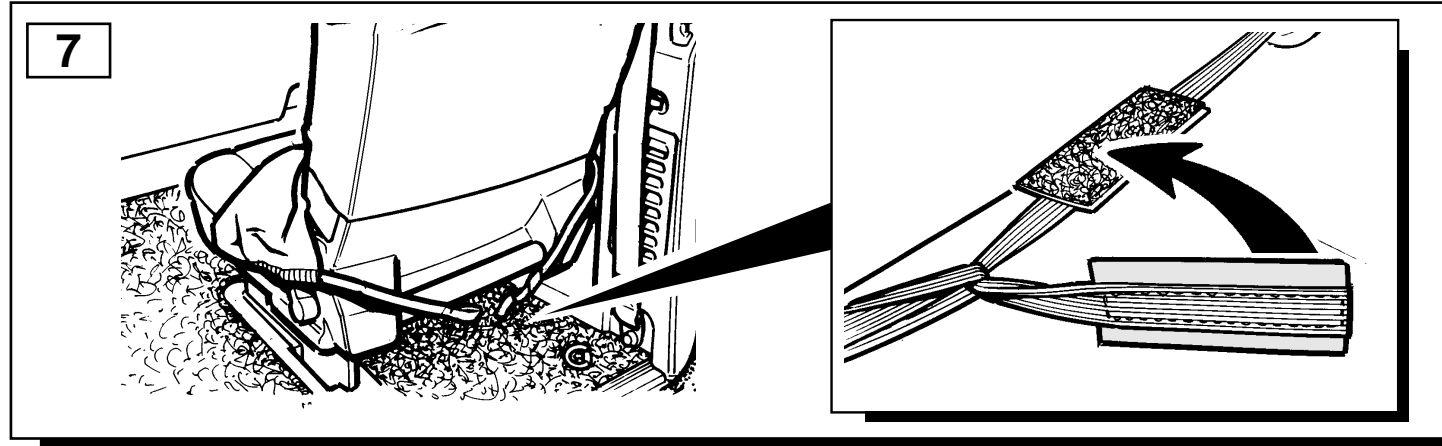

- GB** Follow procedure 9 when stowing seat.
- D** Führen Sie Schritt 9 aus, wenn Sie den Sitz verstauen.
- F** Suivre la procédure 9 pour replier le siège.
- I** Seguire la procedura 9 per stivare il sedile.
- E** Seguir el procedimiento 9 cuando se guarde al asiento.
- P** Siga o procedimento 9 ao guardar o banco.
- NL** Volg procedure 9 voor het opbergen van de bank.
- GR** Επαναλάβετε τη διαδικασία στην άλλη πλευρά 9.
- 日** シート収納時には手順 9 に従ってください

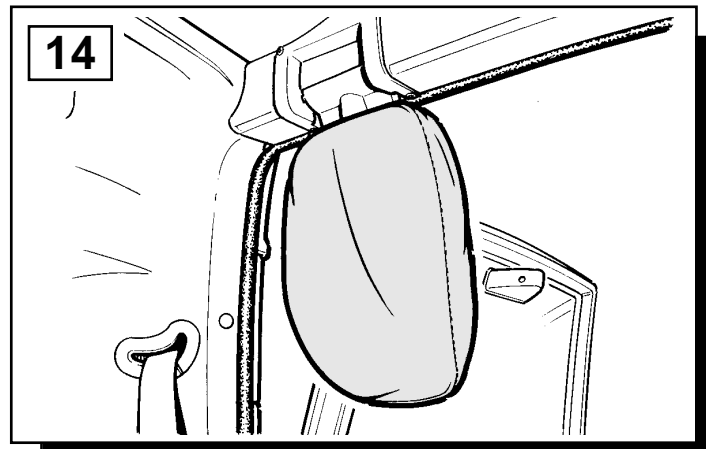
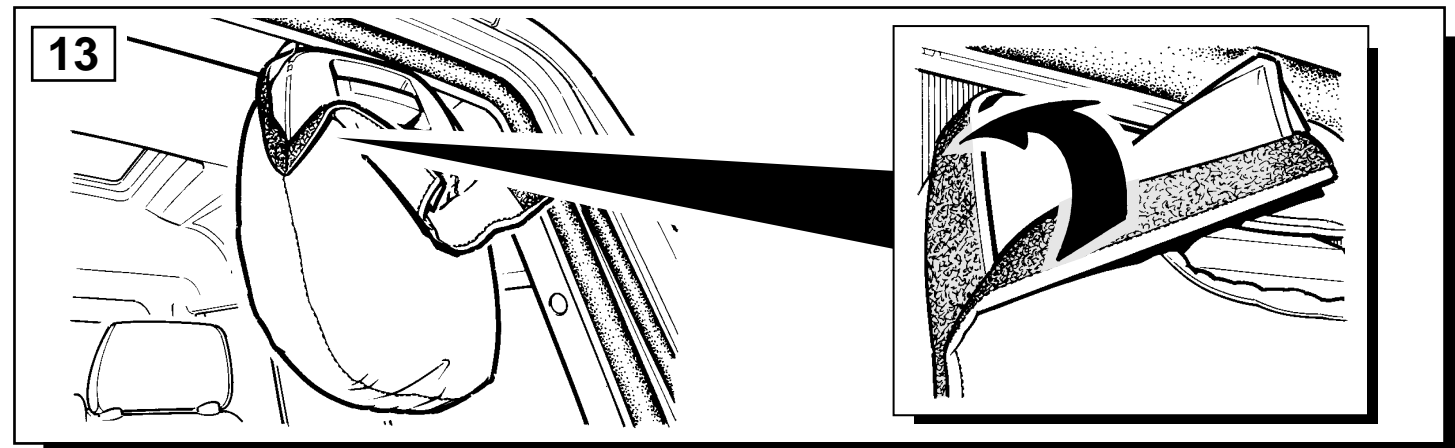
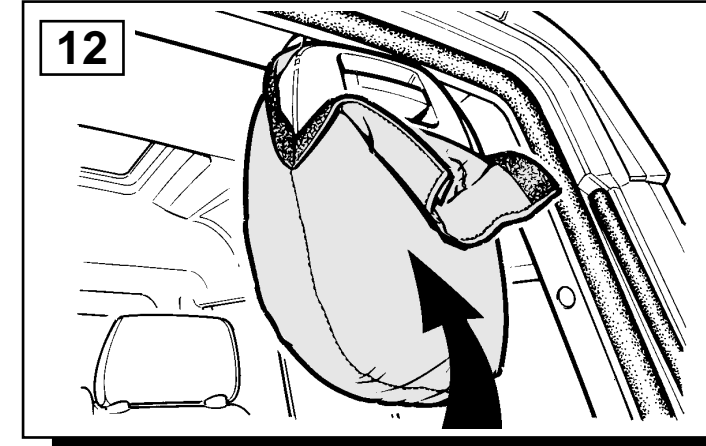
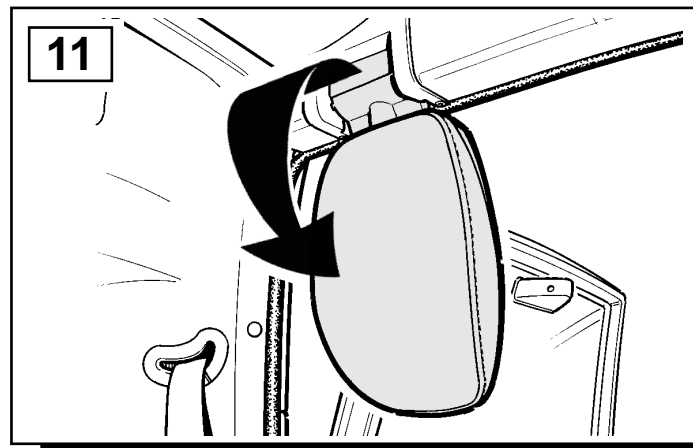
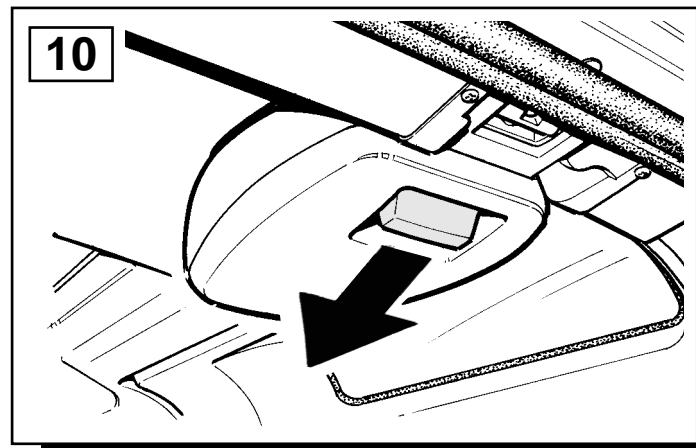

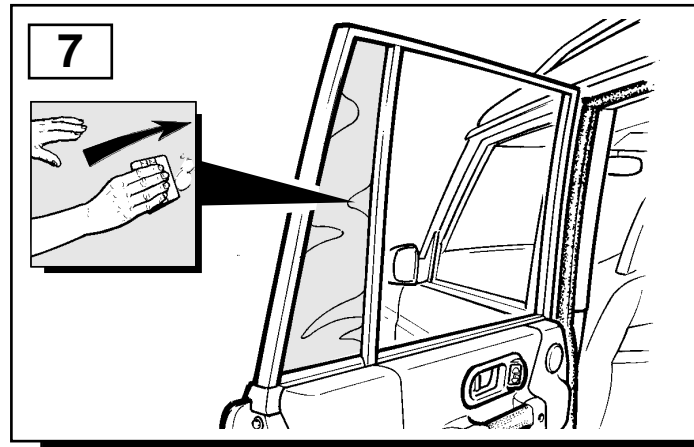
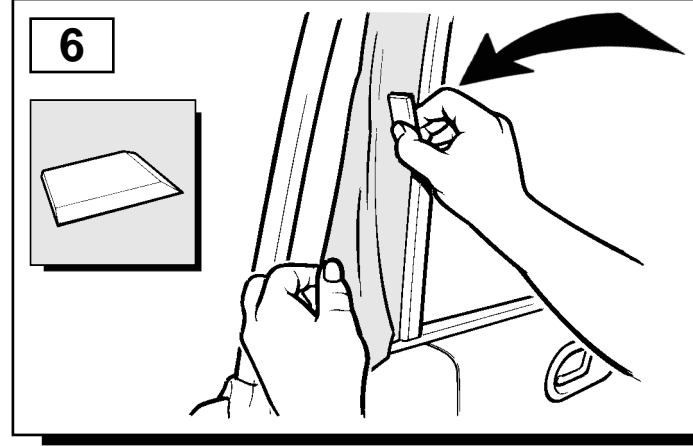
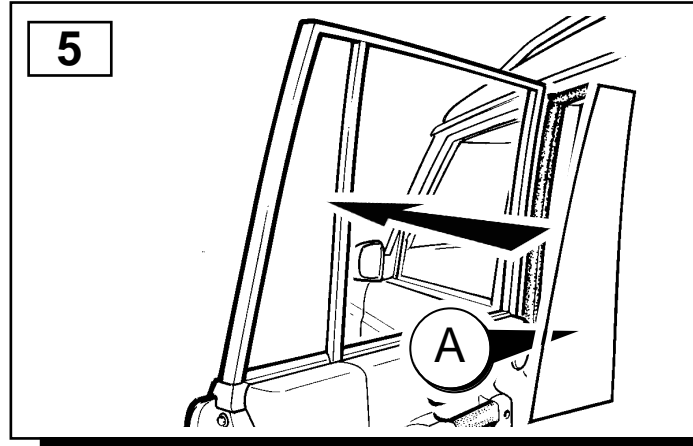

GB The following instructions are valid for both sides of the vehicle.
D Folgende Anweisungen gelten für beide Fahrzeugseiten.
F Les instructions suivantes sont applicables aux deux côtés du véhicule.
I Les istruzioni seguenti sono valide per entrambe le fiancate della Vettura.
E Las siguientes instrucciones son válidas para ambos lados del vehículo.
P As instruções a seguir aplicam-se a ambos os lados do veículo.
NL De volgende instructies zijn van toepassing op beide zijden van de auto.
GR Οι ακόλουθες οδηγίες ισχύουν και για τις δύο πλευρές του οχήματος.
日 次の取付け方法は車の両サイドに適用できます。

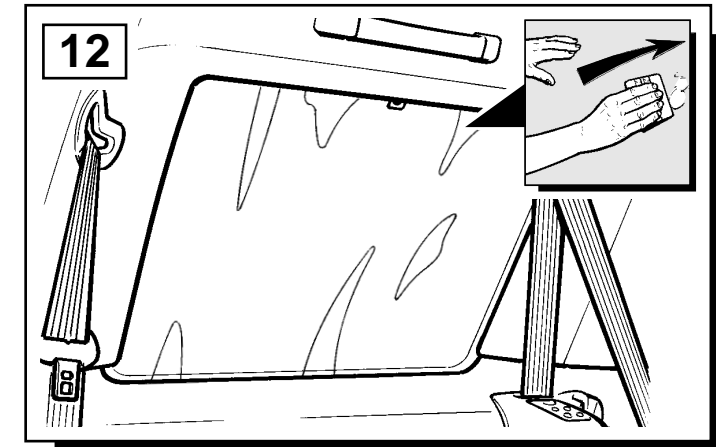
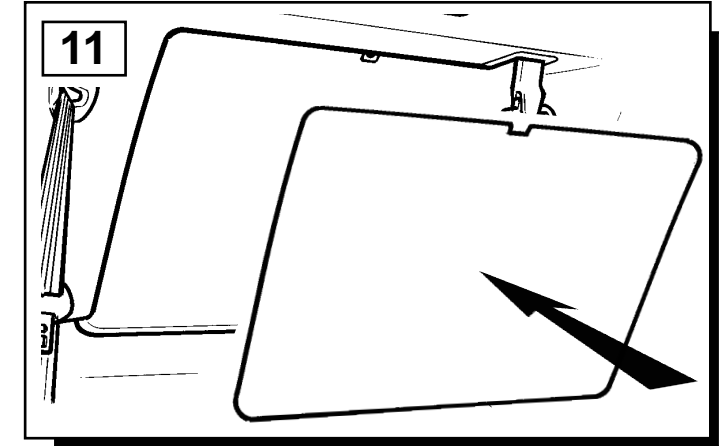
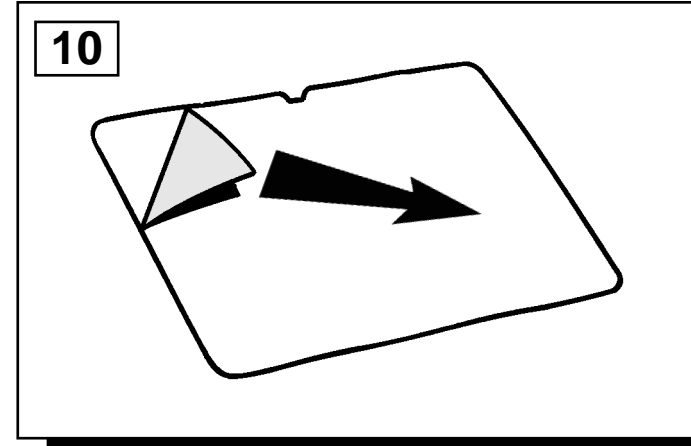
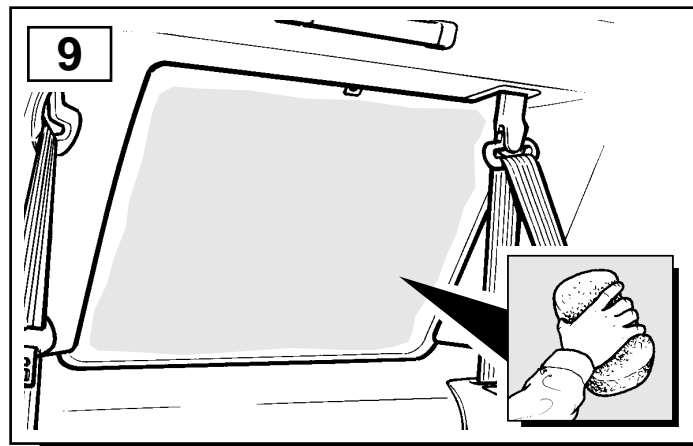
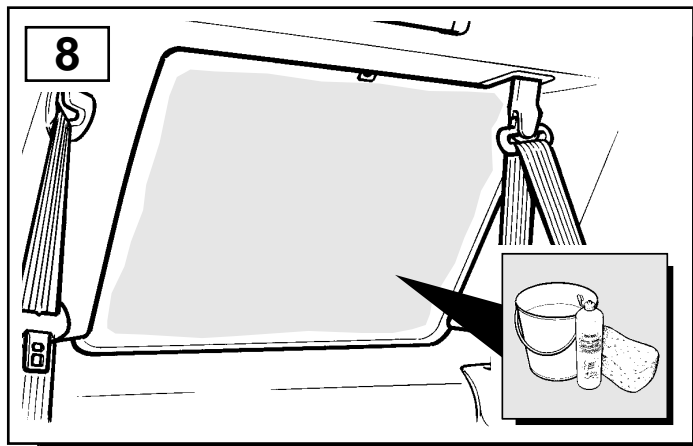
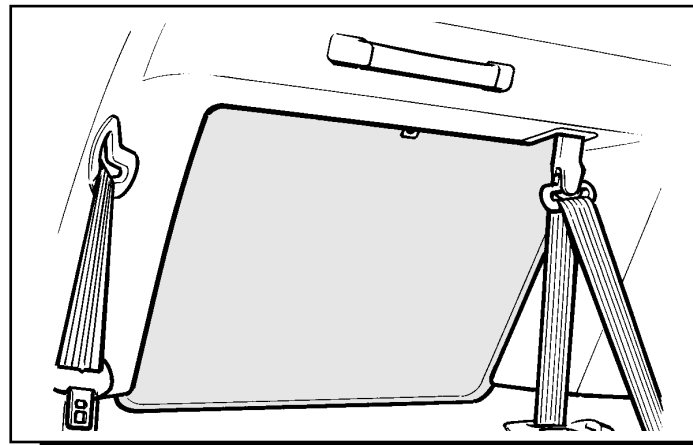

GB The following instructions are valid for both sides of the vehicle.
D Folgende Anweisungen gelten für beide Fahrzeugseiten.
F Les instructions suivantes sont applicables aux deux côtés du véhicule.
I Les istruzioni seguenti sono valide per entrambe le fiancate della Vettura.
E Las siguientes instrucciones son válidas para ambos lados del vehículo.
P As instruções a seguir aplicam-se a ambos os lados do veículo.
NL De volgende instructies zijn van toepassing op beide zijden van de auto.
GR Οι ακόλουθες οδηγίες ισχύουν και για τις δύο πλευρές του οχήματος.
日 次の取付け方法は車の両サイドに適用できます。

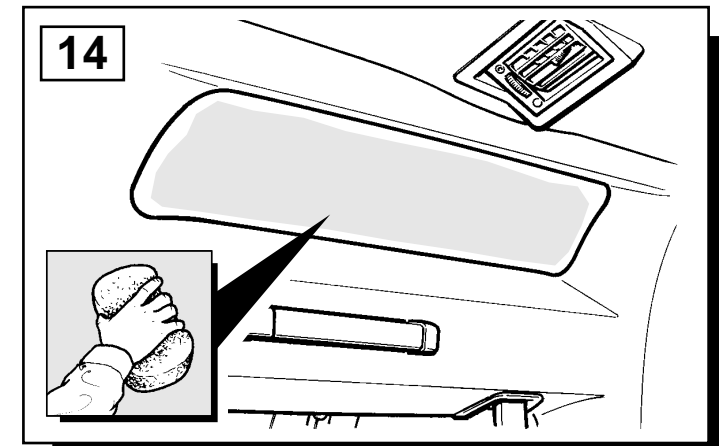
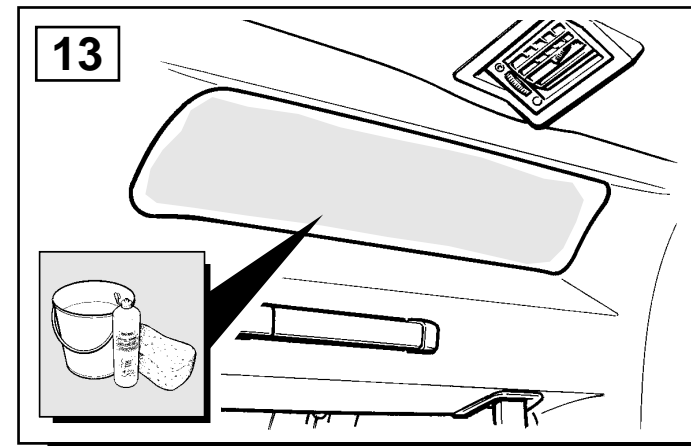
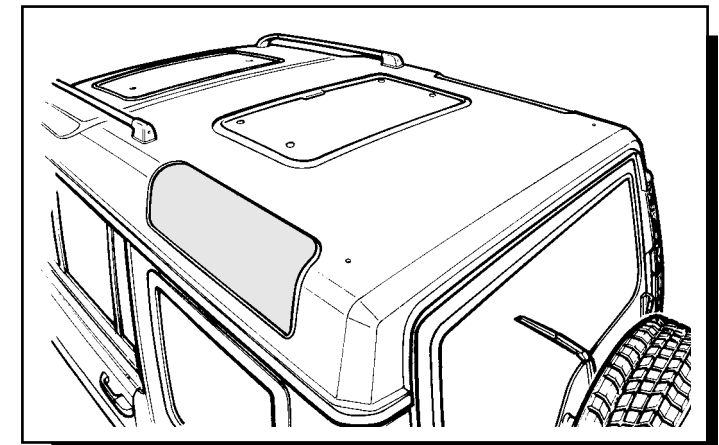

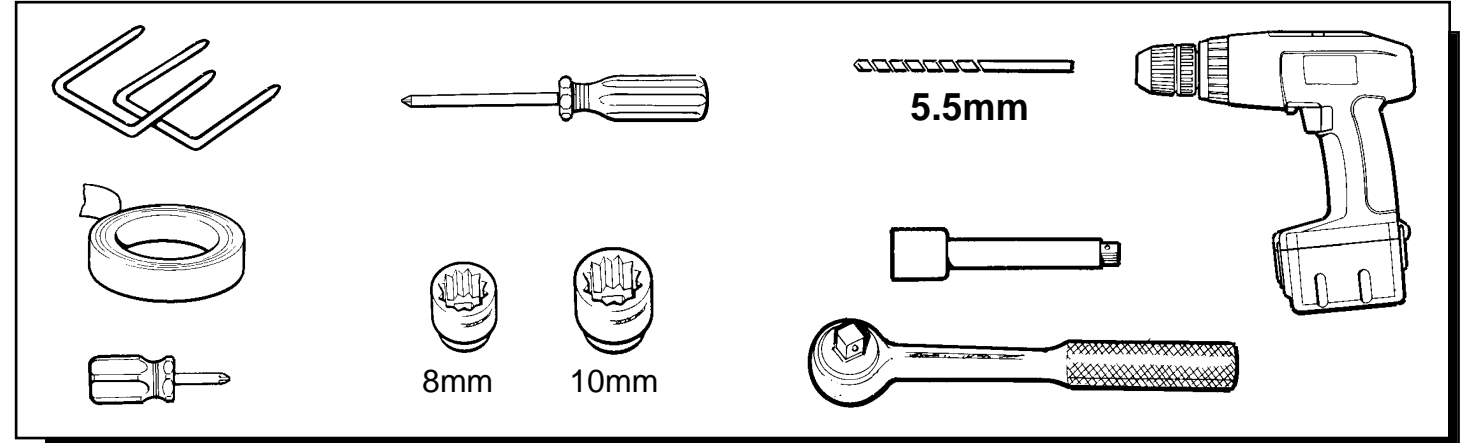
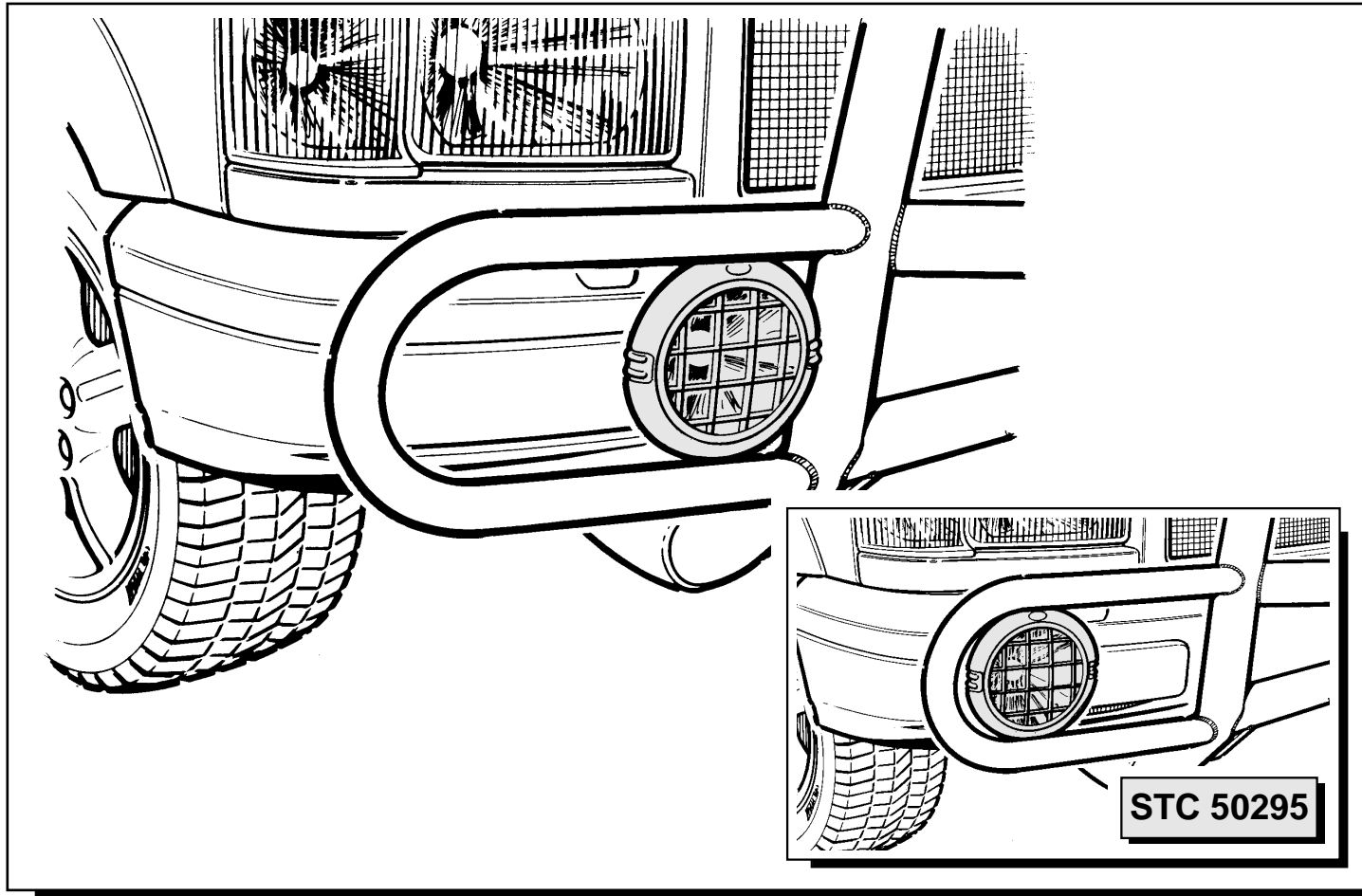

- (GB) Dealer Fit Only.
- (D) Einbau durch Vertragshändler.
- (F) Raccord posé.
- (I) Montaggio fatto da un concessionario.
- (E) Instalación por un concesionario.
- (P) Instalação pelo Concessionário.
- (NL) Montage door de dealer.
- (GR) Τοποθέτηση μόνο από τον Αντιπρόσωπο
- (日) 取付けはディーラーだけが行なうこと。

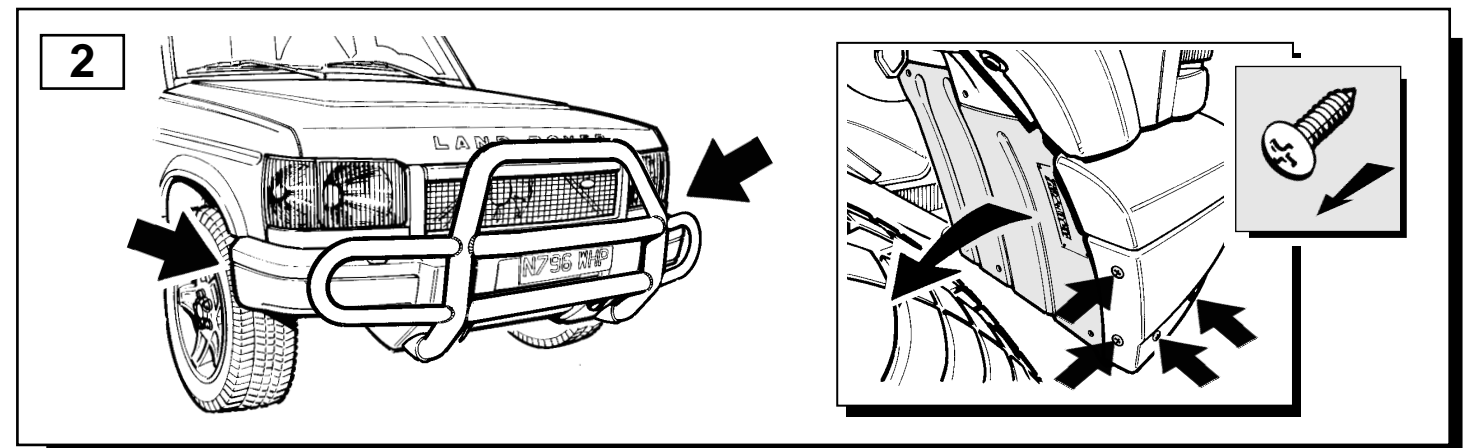
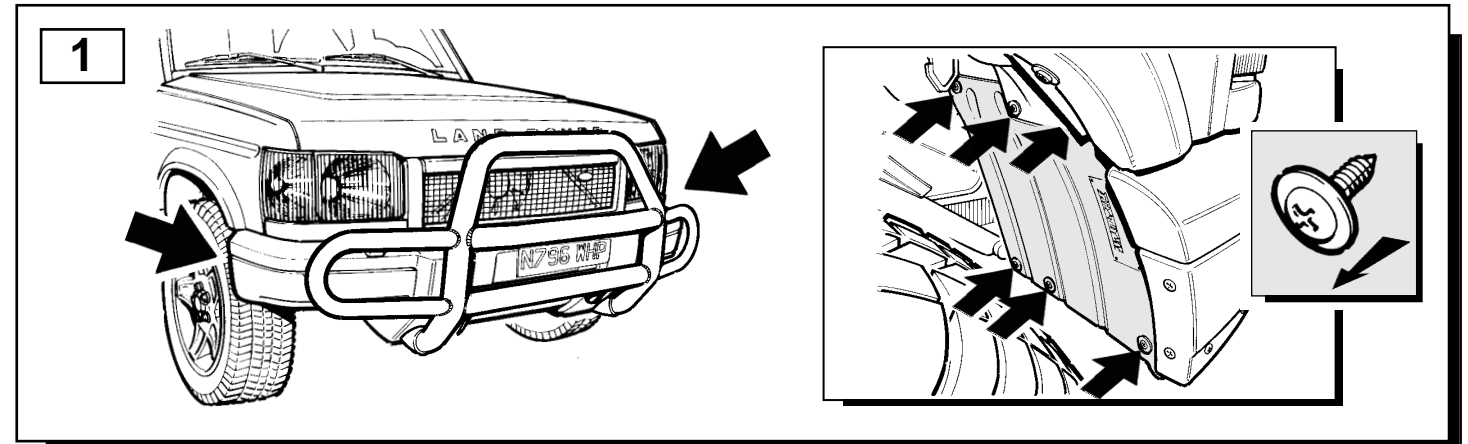
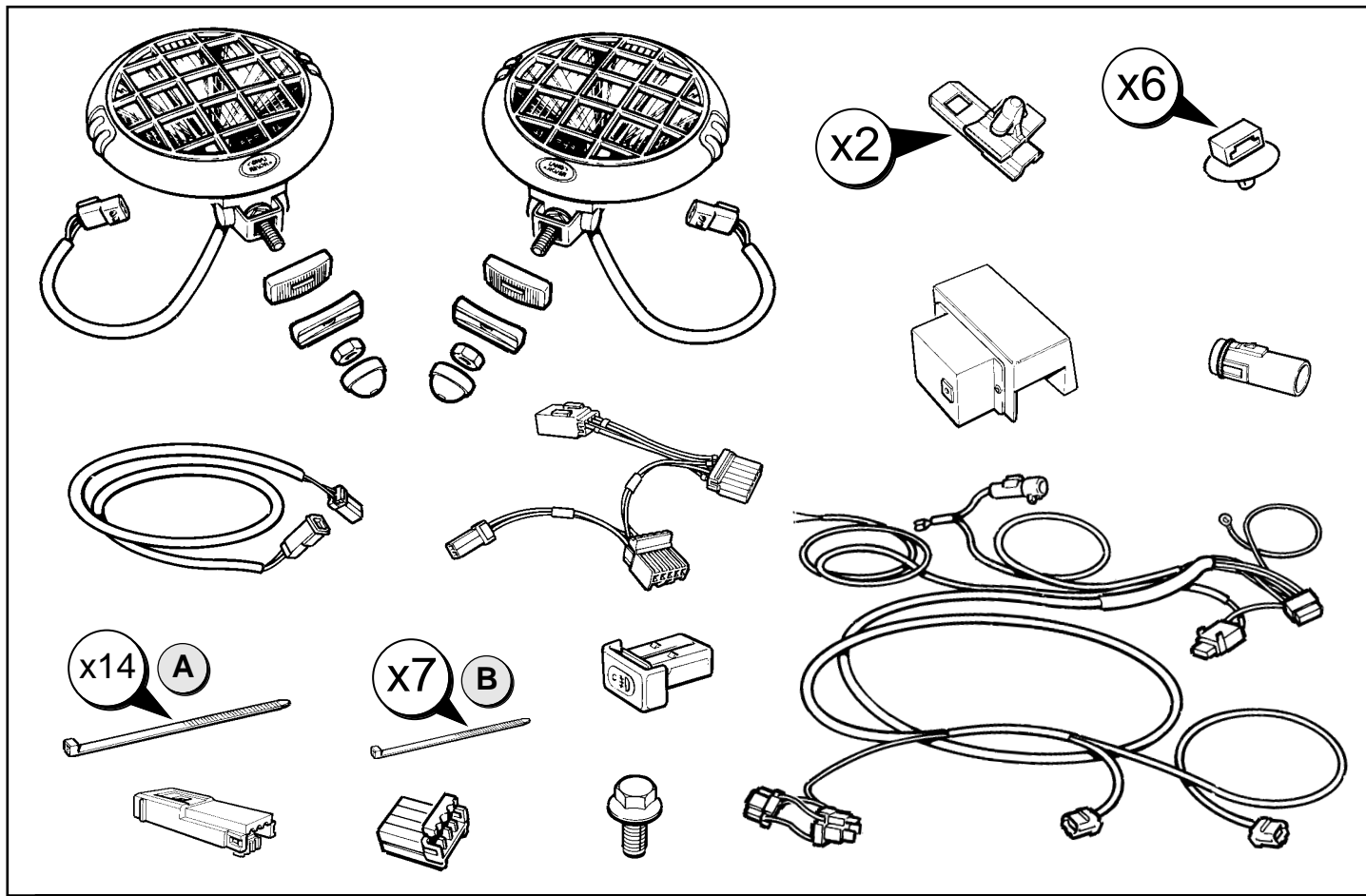

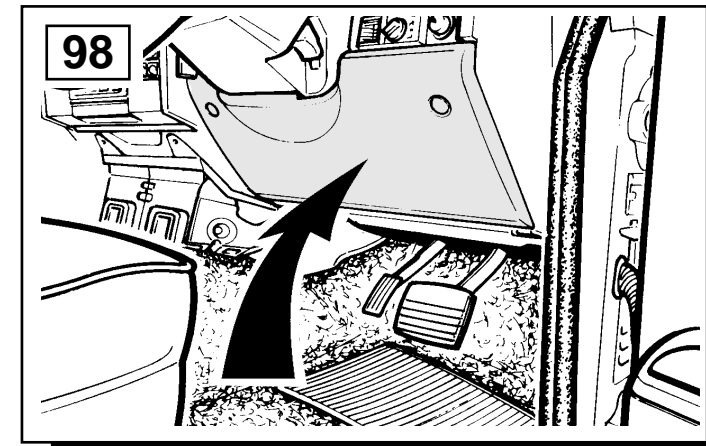
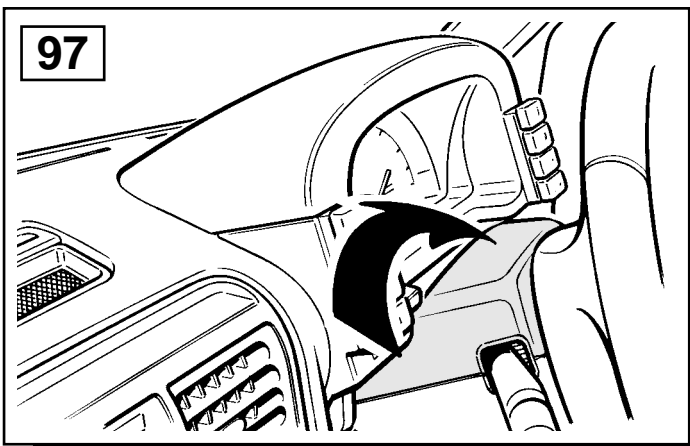
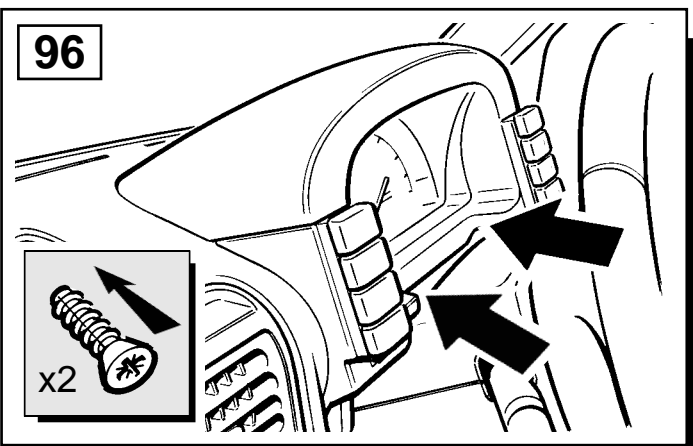
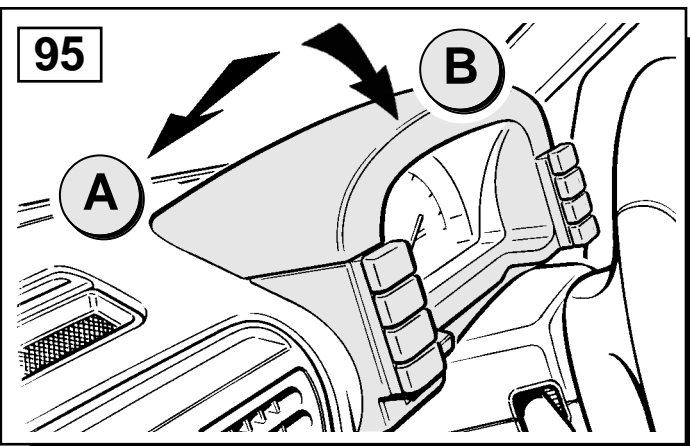
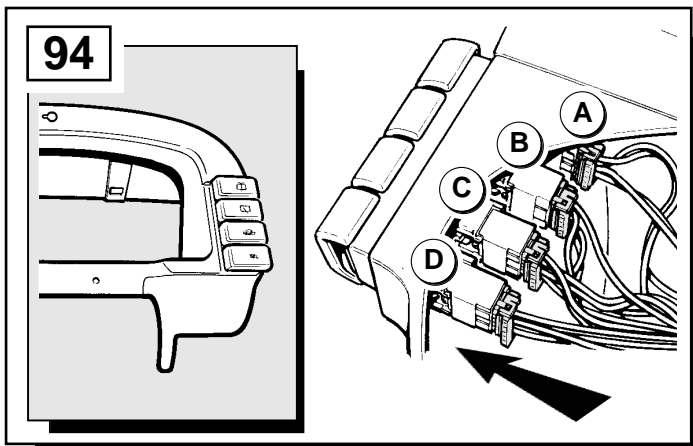
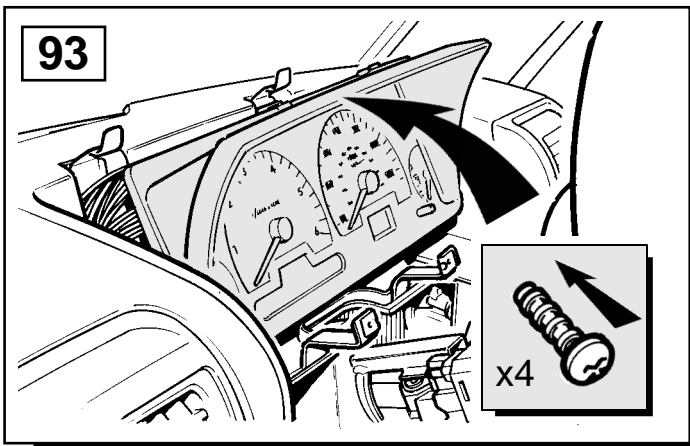
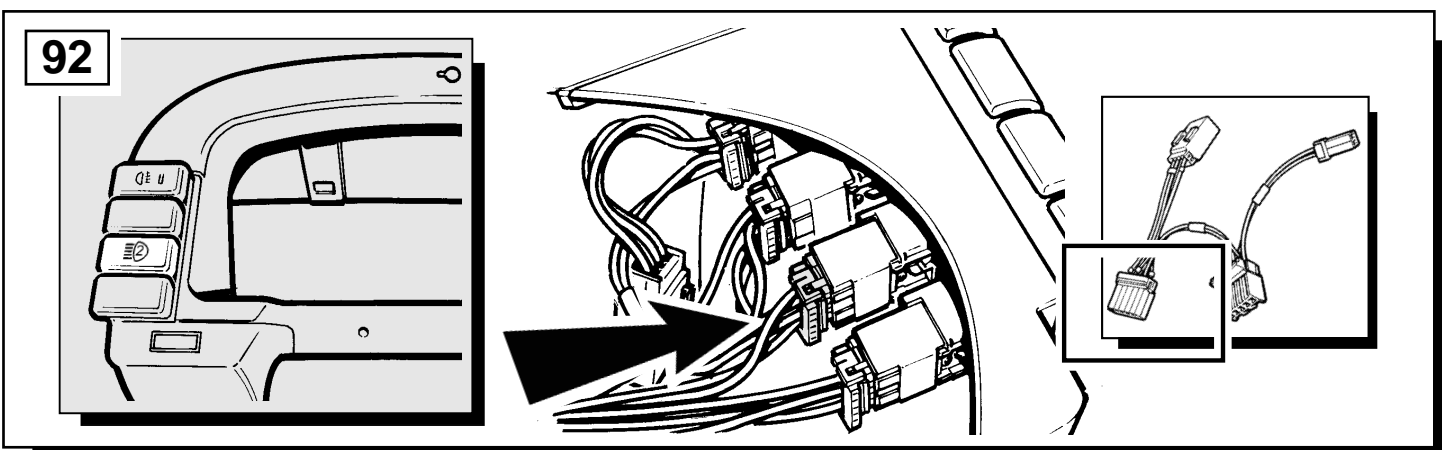
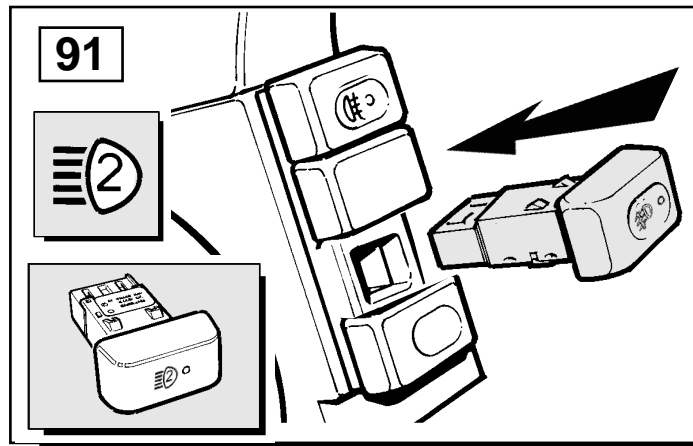
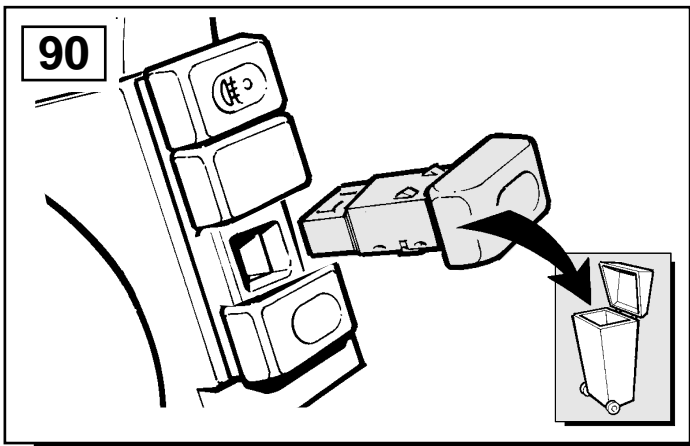

- (GB) LEFT HAND DRIVE
- (D) LINKSSSTEUERU
- (F) CONDUITE A GAUCHE
- (I) VOLANTE A LA IZQUIERDA
- (E) GUIDA A SINISTRA
- (P) DIRECÇÃO À ESQUERDA
- (NL) LINKSGESTUURDE VERSIES
- (GR) ΔΕΞΙΟΤΙΜΟΝΟ
- (H) 左ハンドル

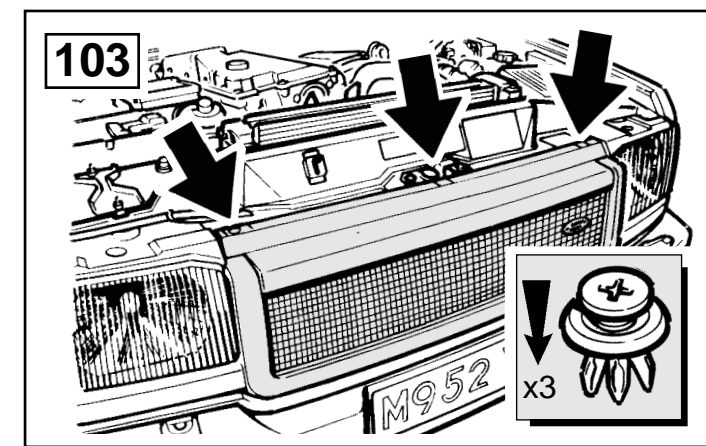
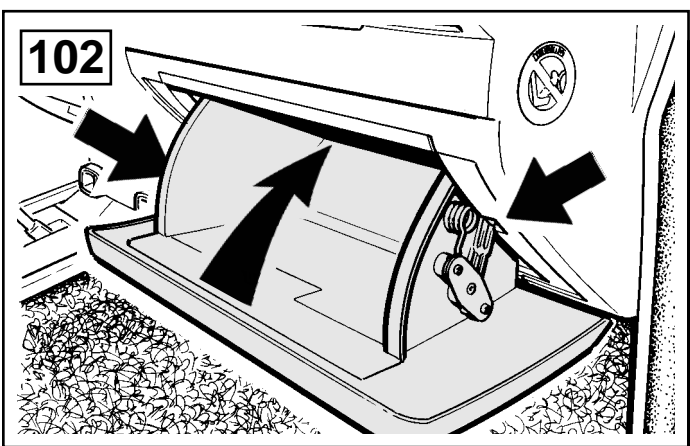
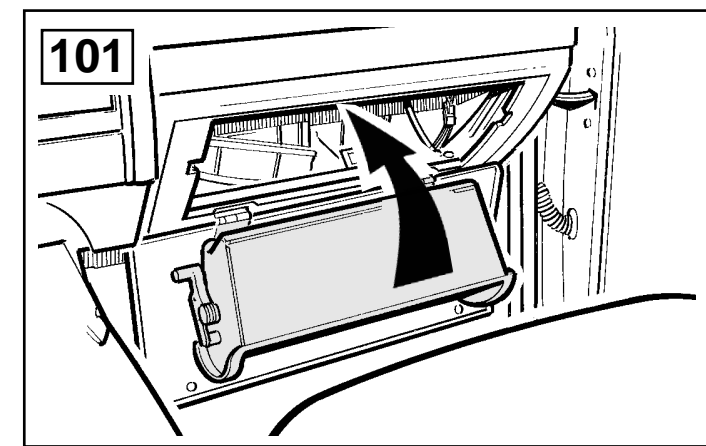
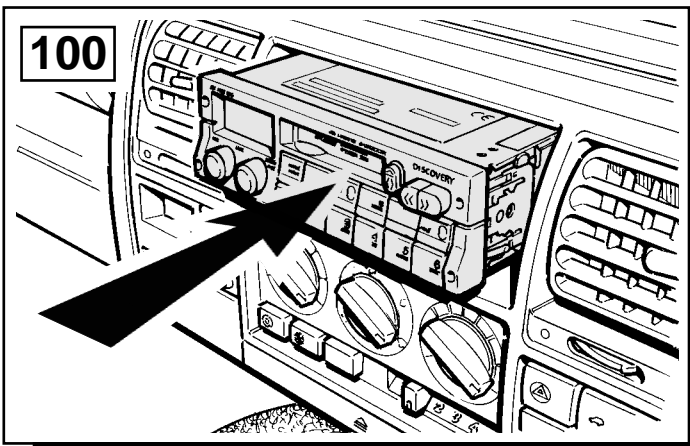
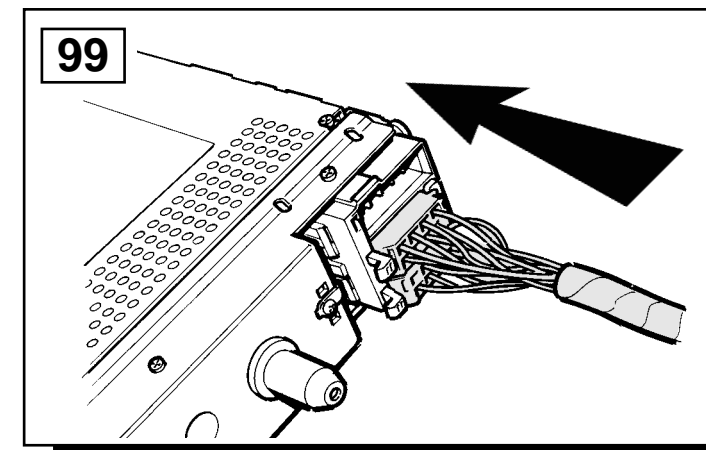

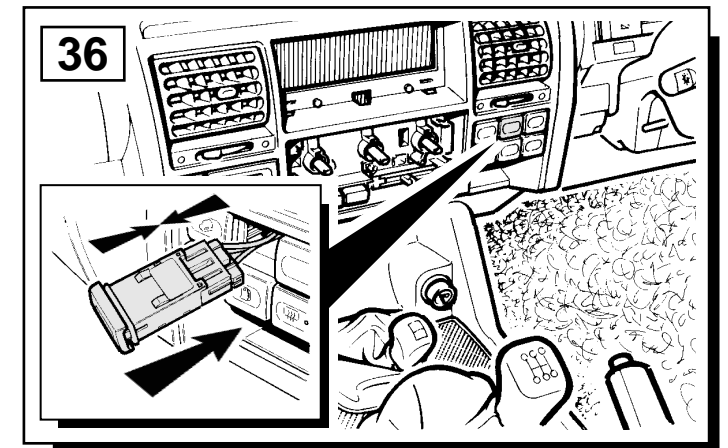
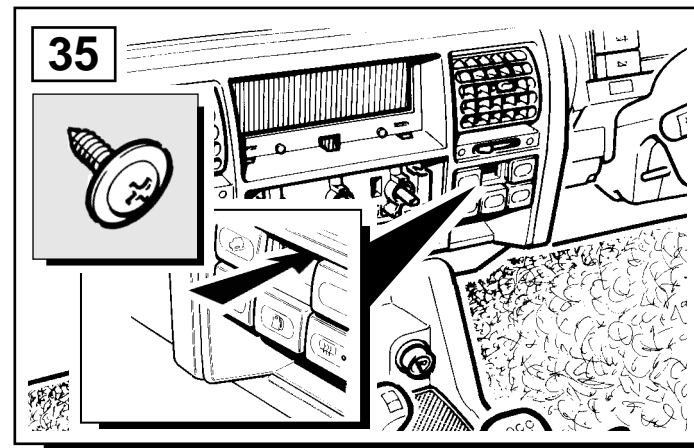
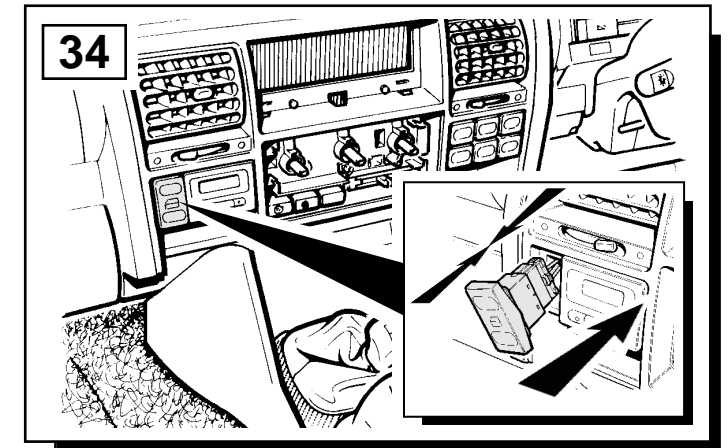
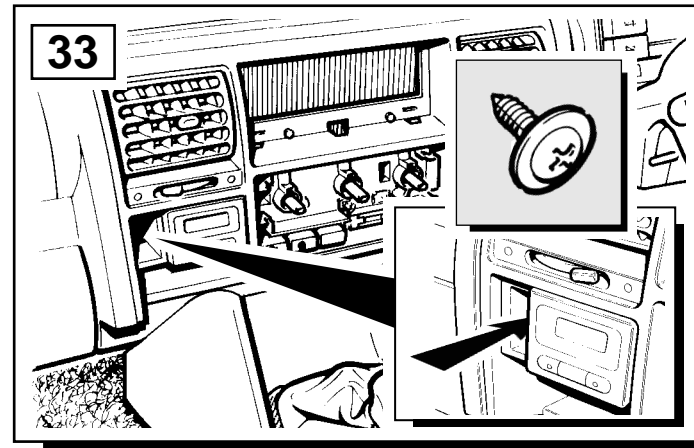
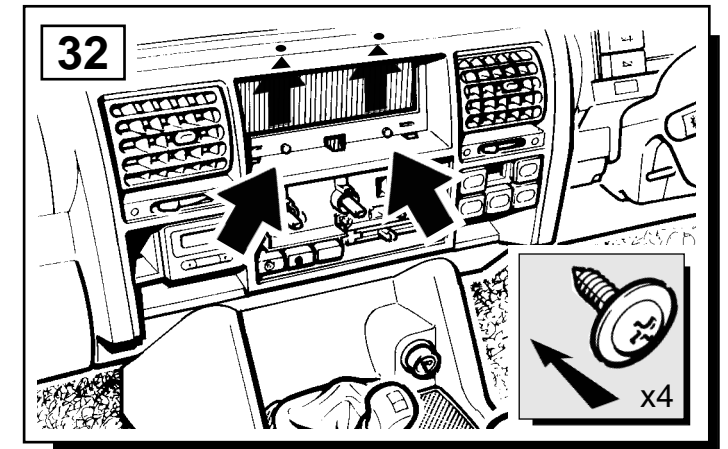
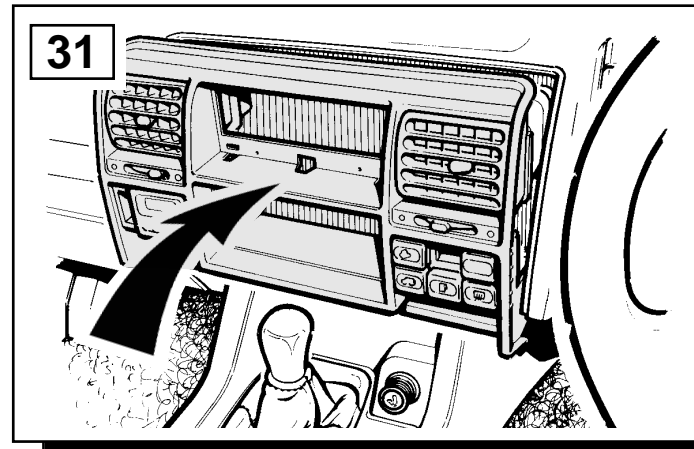
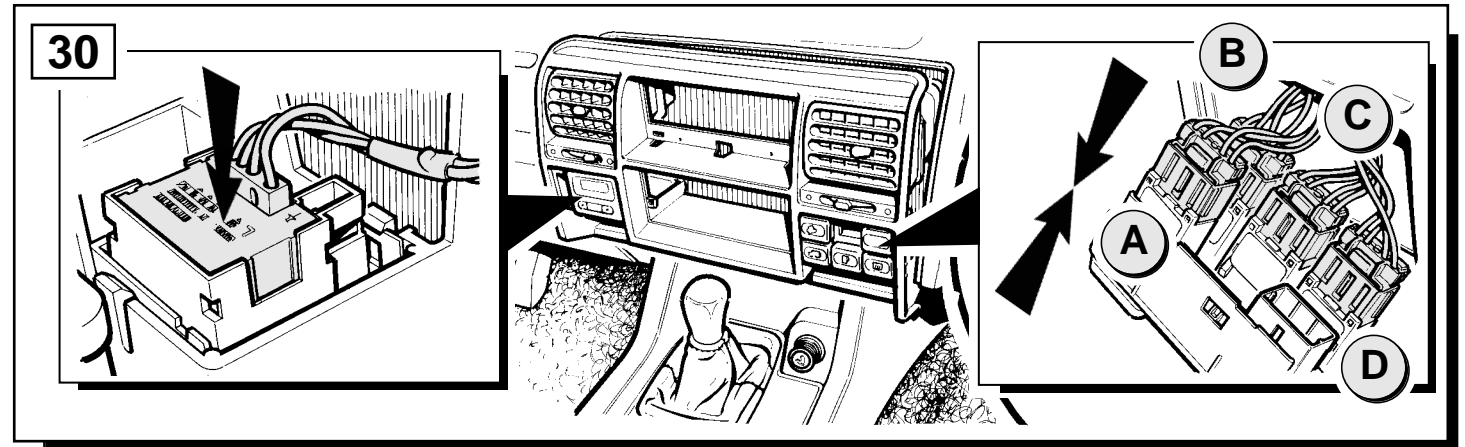
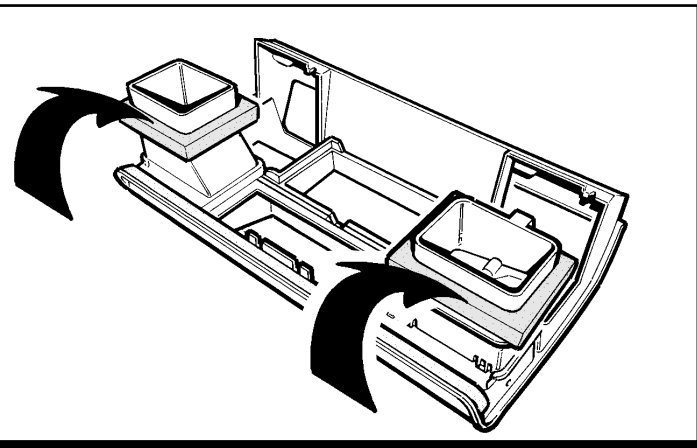
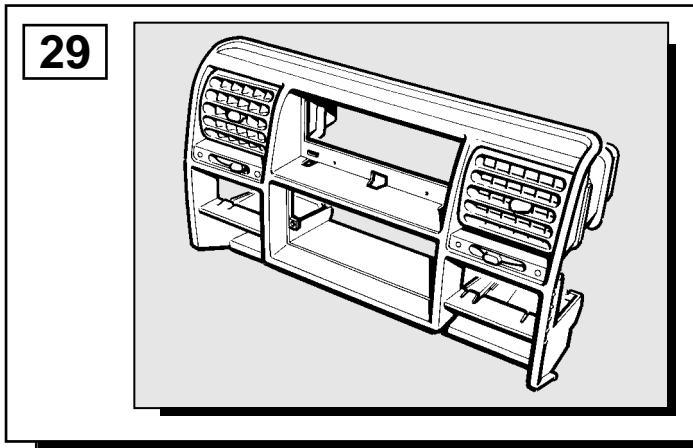
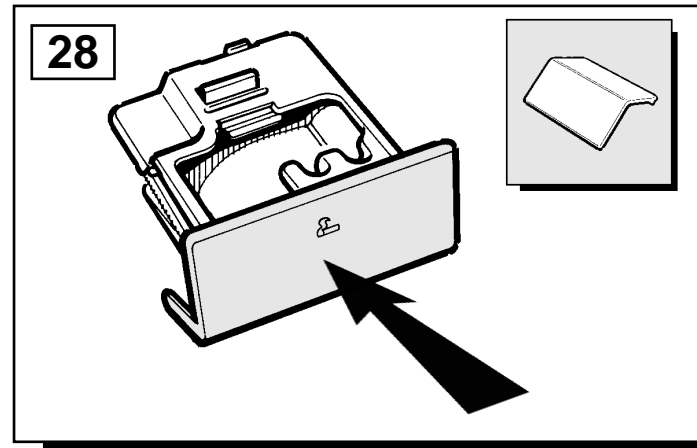
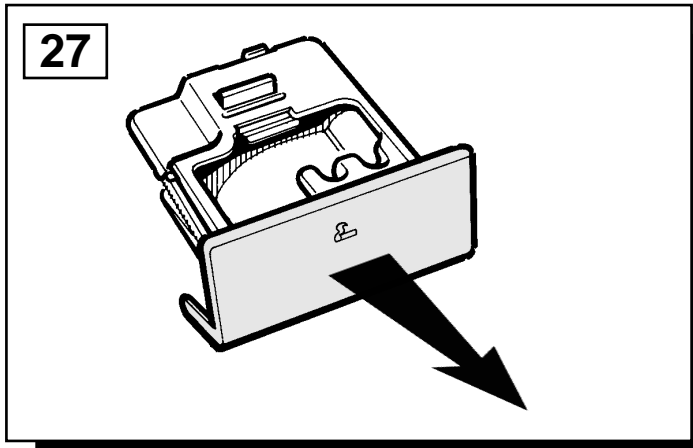
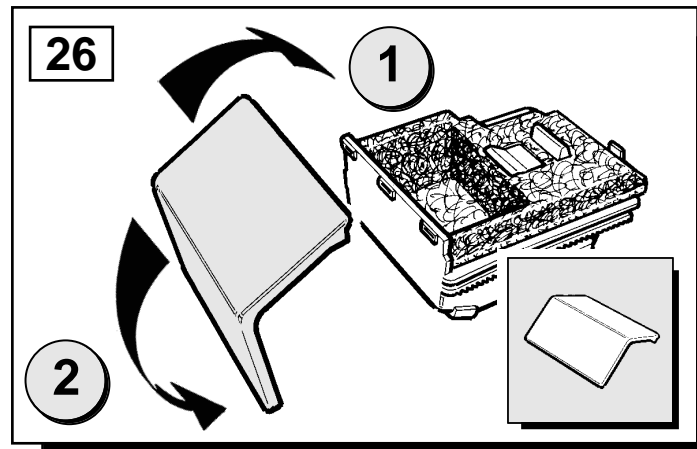
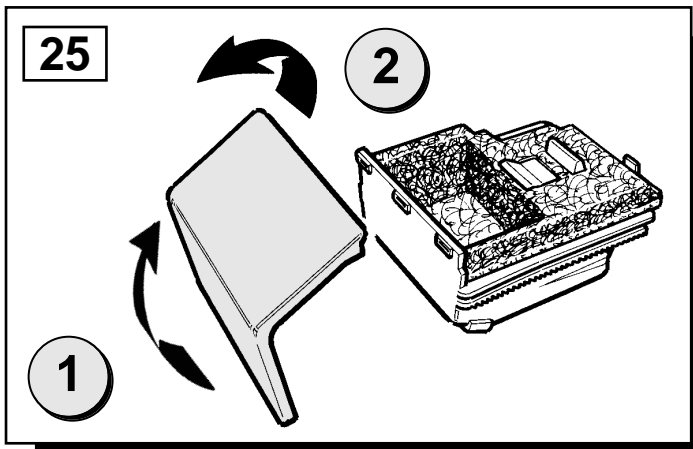
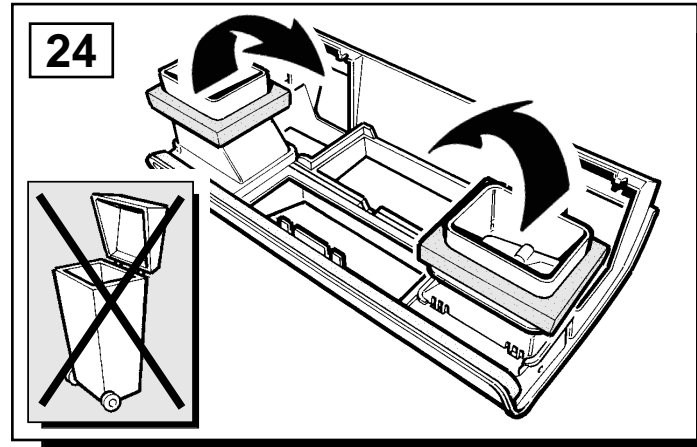
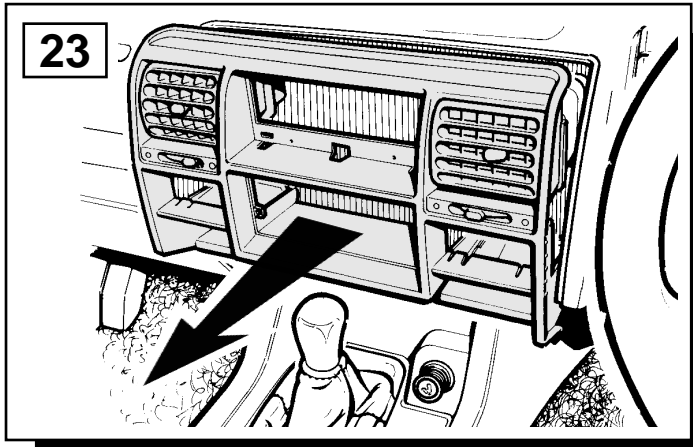



ACCESSORIES

WARNING

Accessories which are not properly fitted can be dangerous. Read the instructions carefully prior to fitting. Whilst fitting, comply with the instructions at all times. If in doubt, contact your nearest Land Rover Dealer.

ACHTUNG!

Nicht sachgemäß montiertes Zubehör kann gefährlich sein. Lesen Sie die Montageanleitung sorgfältig, bevor Sie das Teil montieren. Halten Sie sich bei der Montage an die Anleitung. Bei Unsicherheiten wenden Sie sich bitte an Ihren Land Rover Händler.

AVERTISSEMENT

Les accessoires qui ne sont pas correctement montés risquent d'être dangereux. Veuillez lire soigneusement les instructions avant d'effectuer la pose. Respectez toujours les instructions en cours de pose. En cas de doute, consultez votre concessionnaire Land Rover local.

AVVERTENZA

Gli accessori non sistemati come previsto possono essere pericolosi. Leggere attentamente le istruzioni prima del fissaggio. Durante il montaggio seguire sempre le relative istruzioni. In caso di dubbio rivolgersi al più vicino concessionario della Land Rover.

AVISO

Aquellos accesorios que no hayan sido ajustados debidamente pueden resultar peligrosos. Lea las instrucciones detenidamente antes de iniciar el montaje. Durante el montaje siga las instrucciones en todo momento. En caso de duda póngase en contacto con su Concesionario de Land Rover.

ADVERTÊNCIA!

Os Acessórios que não são montados adequadamente podem ser perigosos. Leia as instruções cuidadosamente antes de montar. Durante a montagem, obedeça as instruções todo o tempo. Se tiver alguma dúvida, contacte o Concessionário LandRover mais próximo.

WAARSHCUWING

Accessoires die niet op de juiste wijze zijn gemonteerd kunnen gevaar opleveren. Lees zorgvuldig de instructies alvorens met de montage te beginnen. Houd u tijdens de montage te allen tijde aan de instructies. Neem bij twijfel contact op met de dichtstbijzijnde Land Rover dealer.

ΠΡΟΕΙΔΟΠΟΙΗΣΗ

Τα προαιρετικά εξαρτήματα που δεν έχουν τοποθετηθεί σωστά μπορεί να είναι επικίνδυνα. Διαβάστε τις οδηγίες πριν προχωρήσετε στην τοποθέτησή τους. Κατά την τοποθέτηση, τηρείτε συνεχώς τις οδηγίες. Αν έχετε οποιαδήποτε αμφιβολία, επικοινωνήστε με τον πλησιέστερο αντιπρόσωπο της.

注意

正しく取り付けられていない備品があると、事故の原因になります。取付ける前にこのマニュアルをよくお読みください。取付けの際は必ずこのマニュアルにある指示に従ってください。何か不明な点がありましたら、お近くのランド・ローバー社のディーラーまでお問い合わせください。



FITTING INSTRUCTION

Fog Lamp Cut-out

EINBAUANLEITUNG

Nebelschlußleuchten-Abschaltung

INSTRUCTION DE MONTAGE

Coupure de feux antibrouillard

ISTRUZIONI PER L'USO

Dispositivo di esclusione fari fendinebbia

INSTRUCCIONES DE MONTAJE

Conmutador para faro antiniebla del remolque

INSTRUÇÕES DE MONTAGEM

Comutação do Farol de Nevoeiro

MONTAGEHANDLEIDING

Schakeling voor mistachterlicht bij aanhangergebruik

ΟΔΗΓΙΑ ΤΟΠΟΘΕΤΗΣΗΣ

Μεταγωγή των Φώτων Ομίχλης στη Ρυμούλκα

取付用マニュアル

フォグランプ カット-アウト

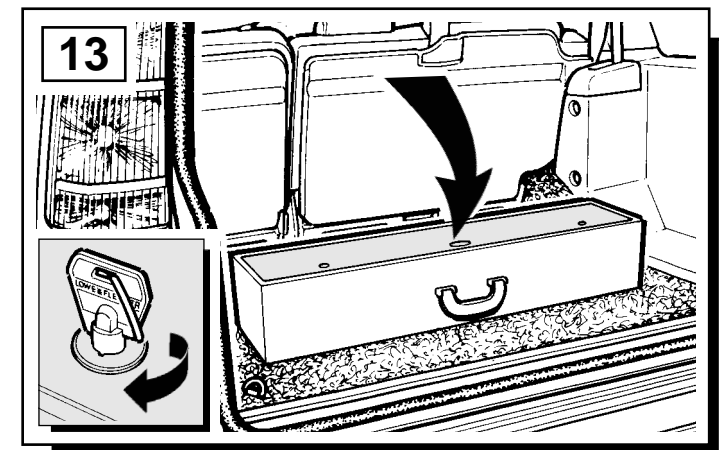
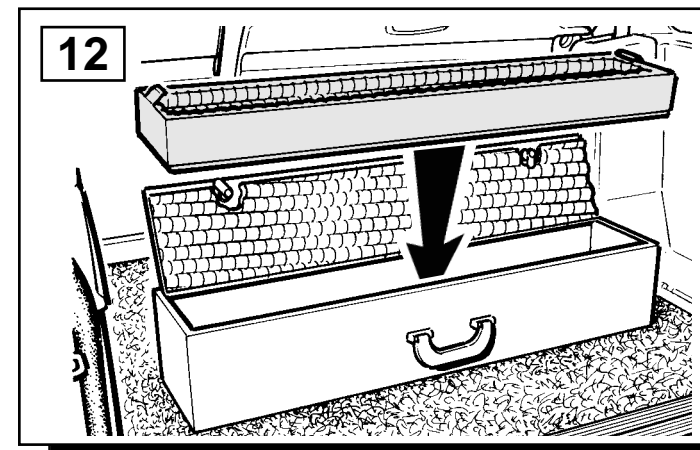
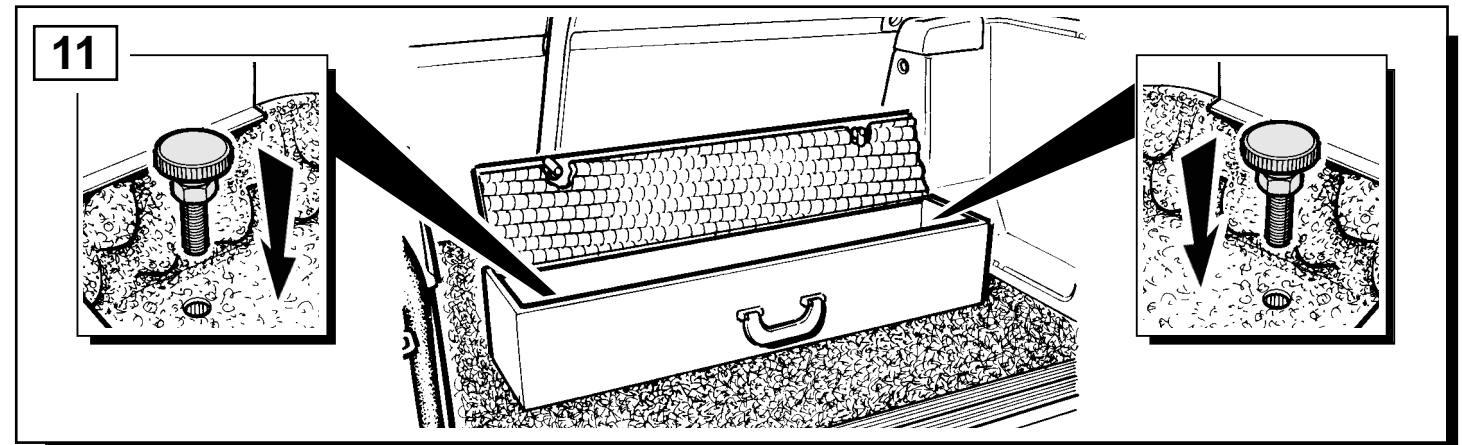
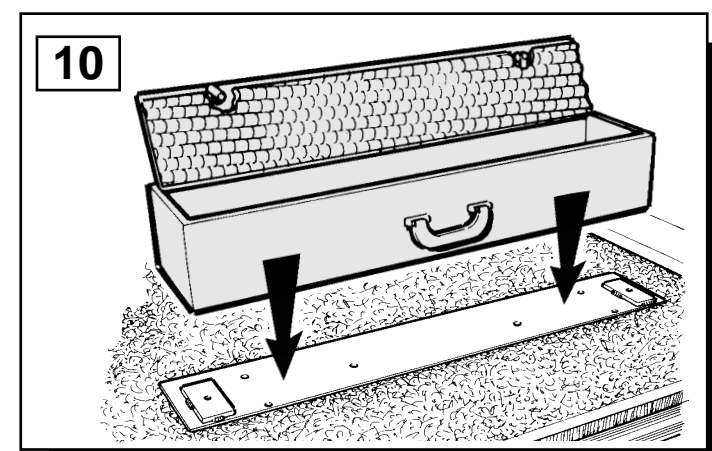
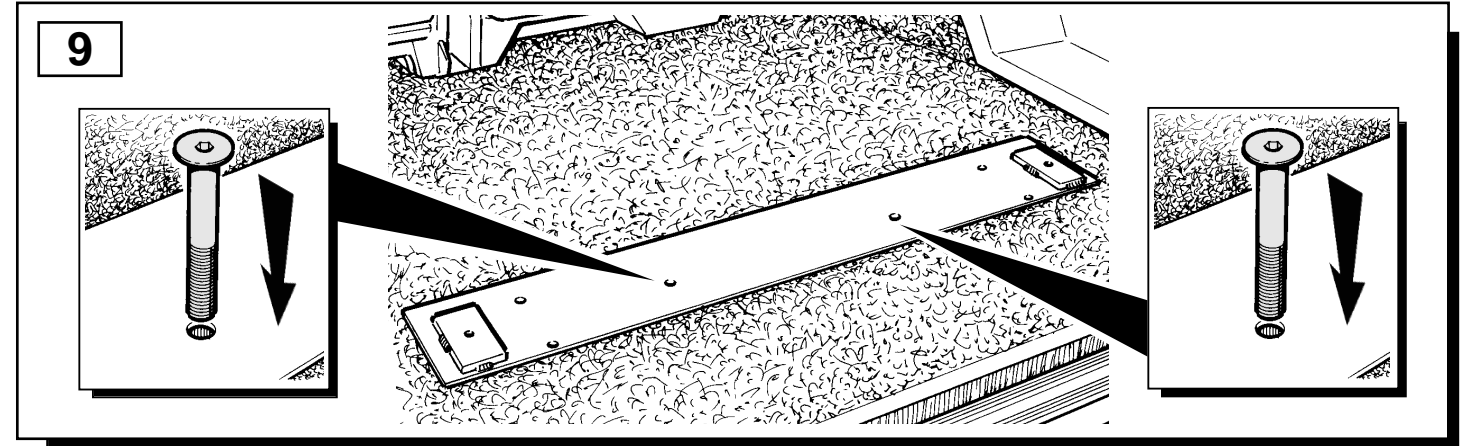
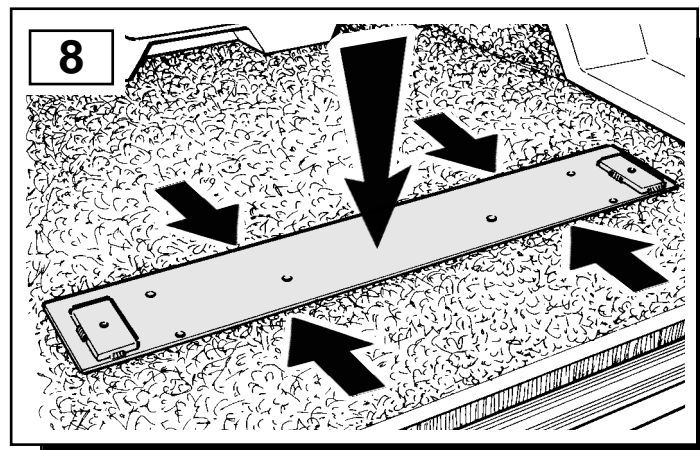
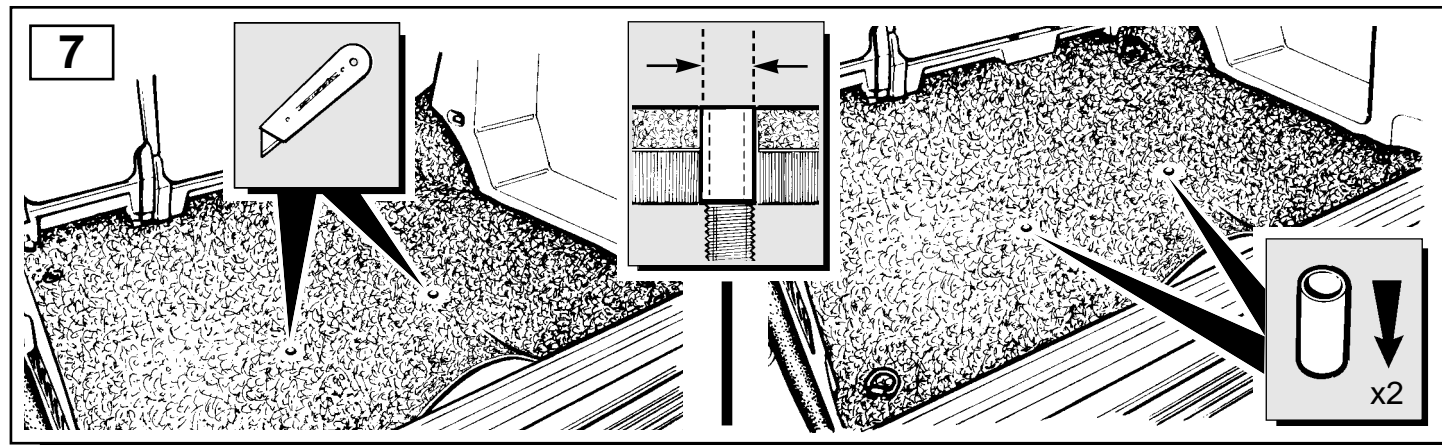
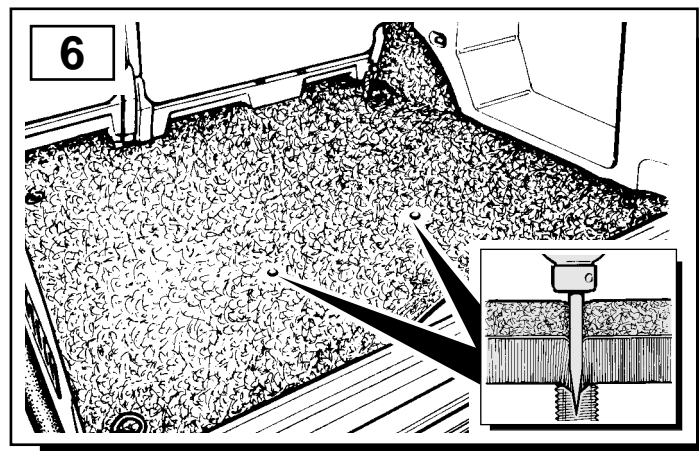
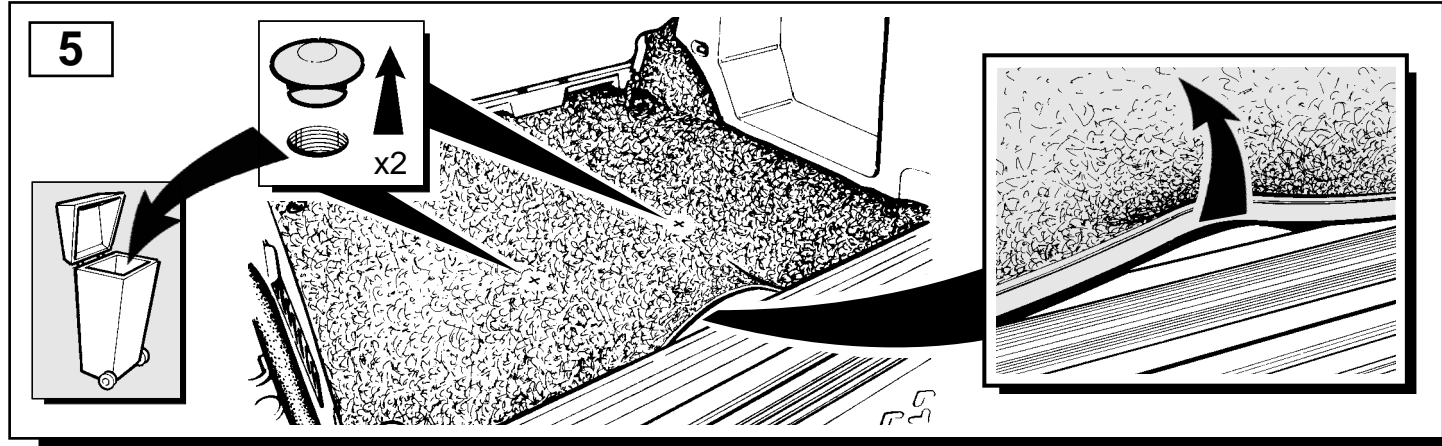

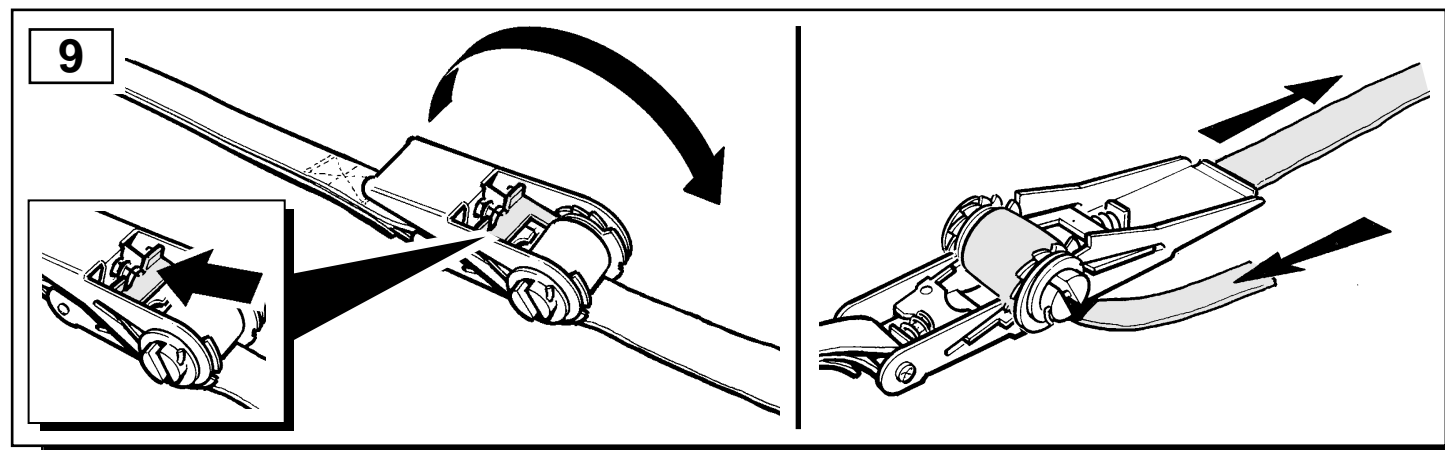
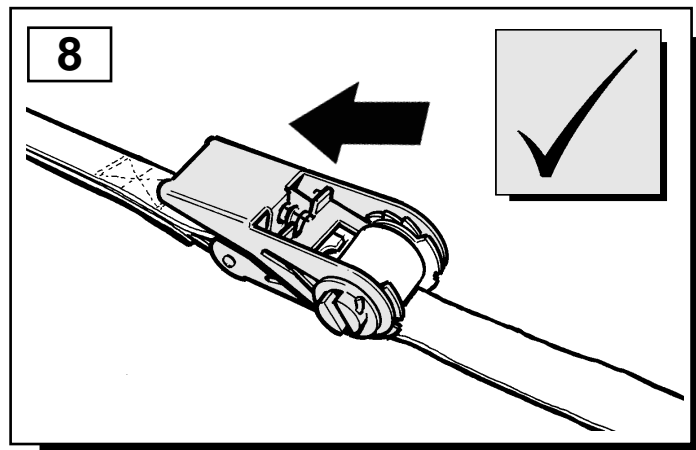
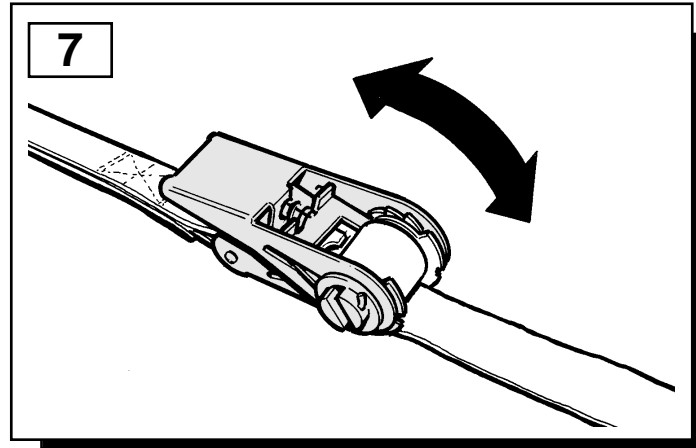
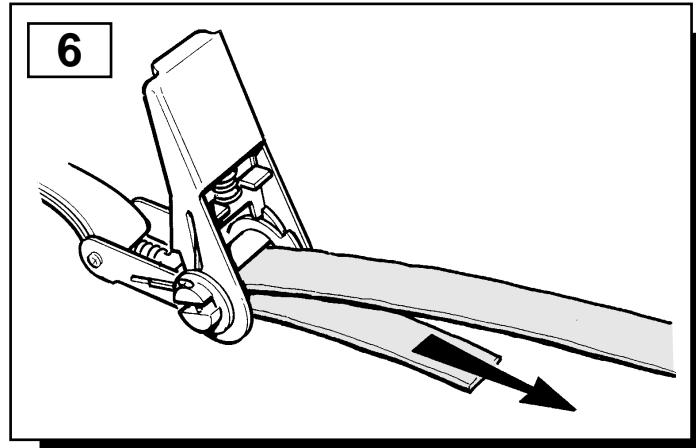

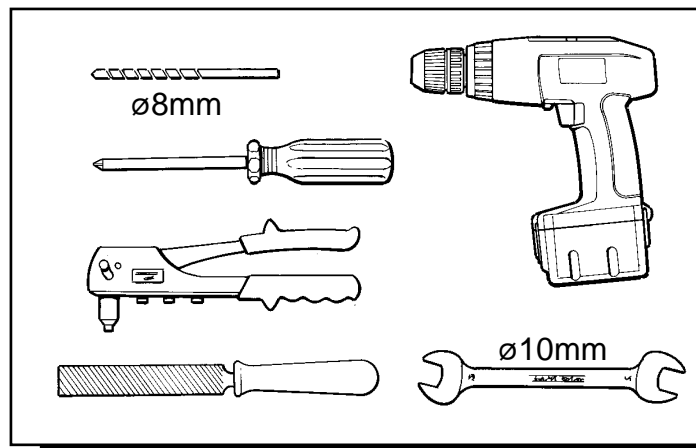
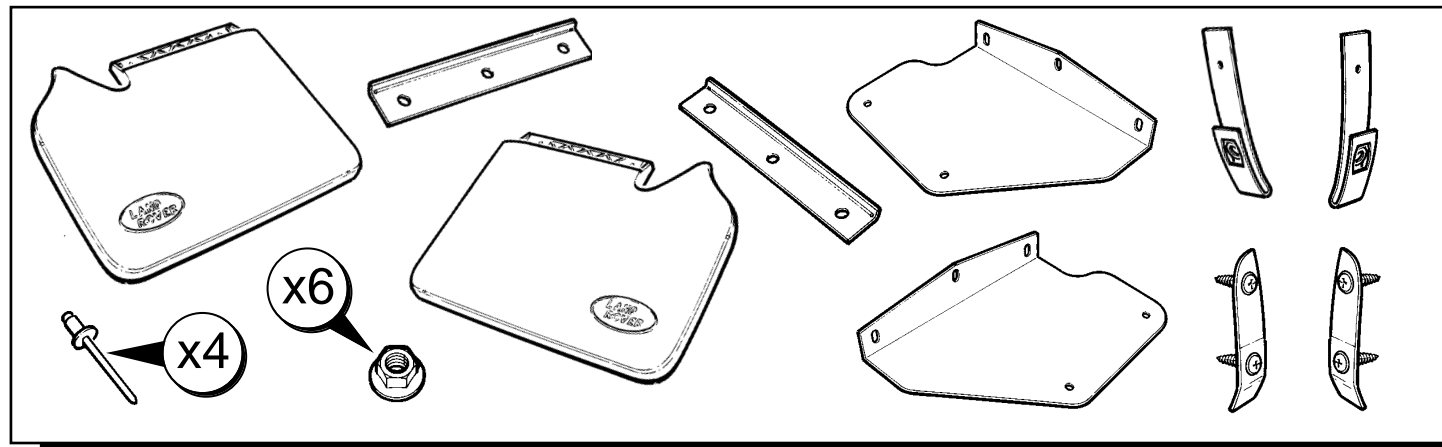
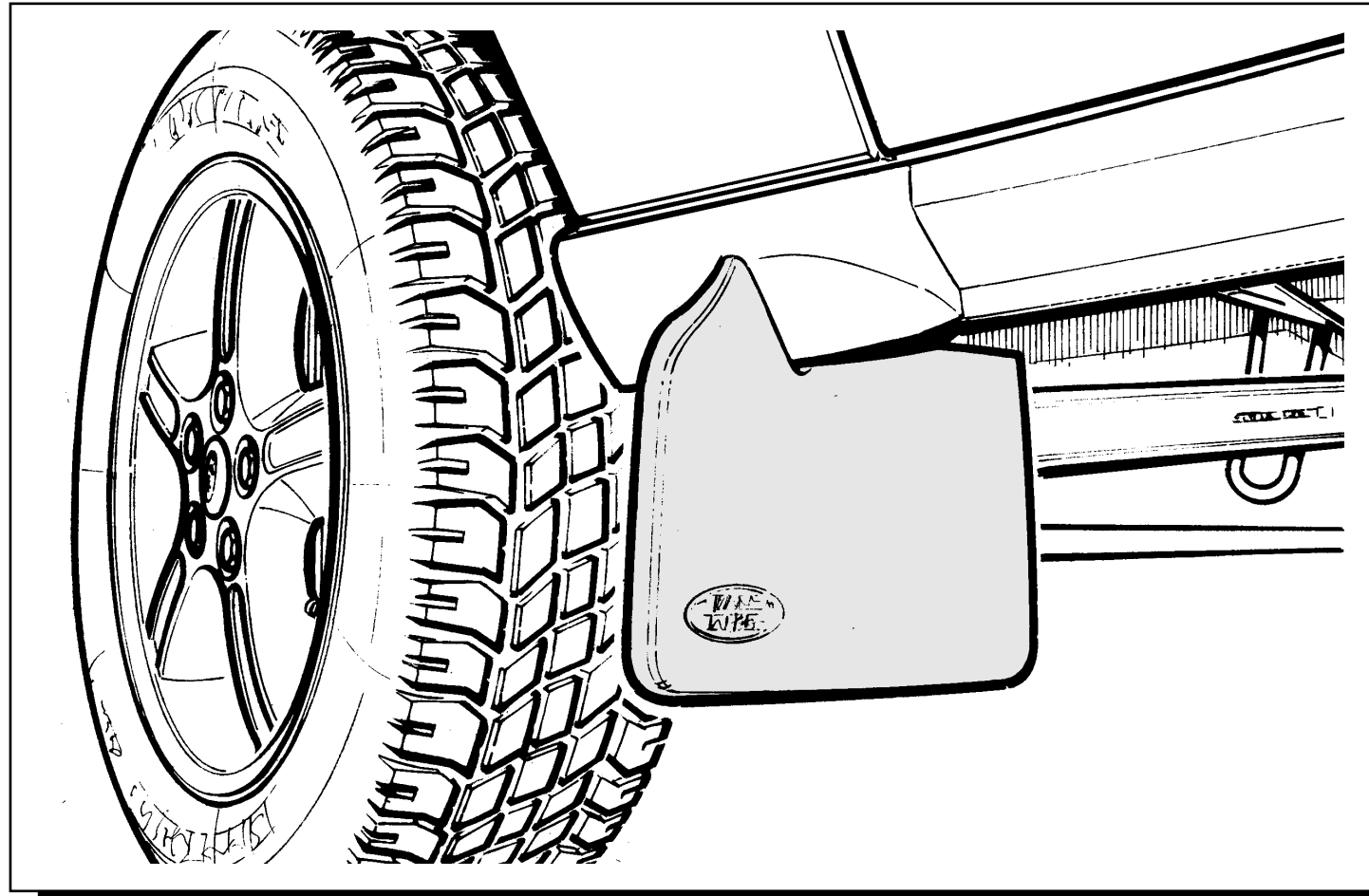

- (GB)** The following instructions are valid for both sides of the vehicle.
- (D)** Folgende Anweisungen gelten für beide Fahrzeugseiten.
- (F)** Les instructions suivantes sont applicables aux deux côtés du véhicule.
- (I)** Les istruzioni seguenti sono valide per entrambe le fiancate della Vettura.
- (E)** Las siguientes instrucciones son válidas para ambos lados del vehículo.
- (P)** As instruções a seguir aplicam-se a ambos os lados do veículo.
- (NL)** De volgende instructies zijn van toepassing op beide zijden van de auto.
- (GR)** Οι ακόλουθες οδηγίες ισχύουν και για τις δύο πλευρές του οχήματος.
- (日)** 次の取付け方法は車の両サイドに適用できます。

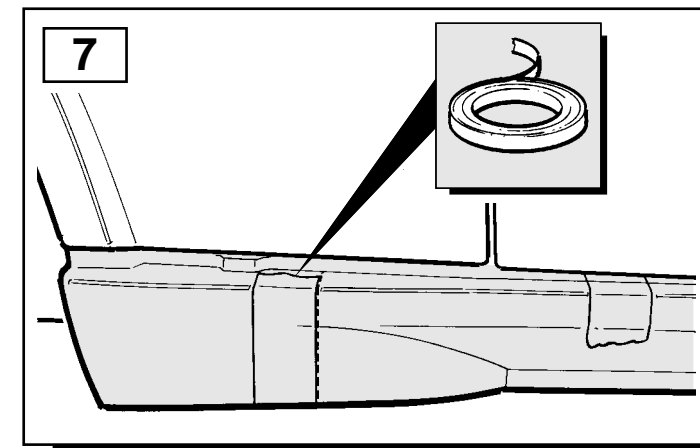
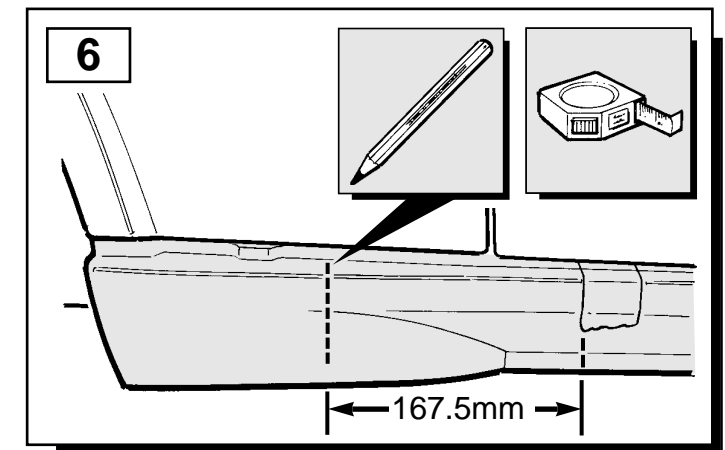
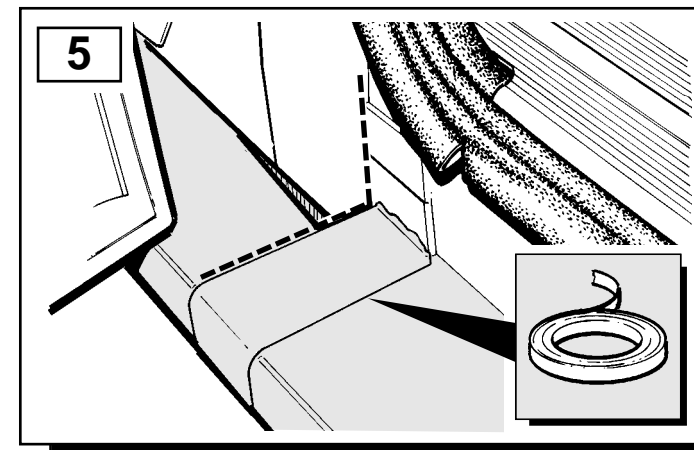
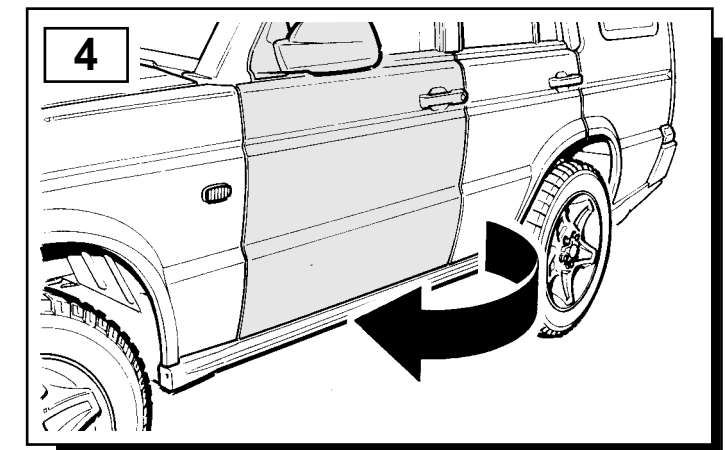
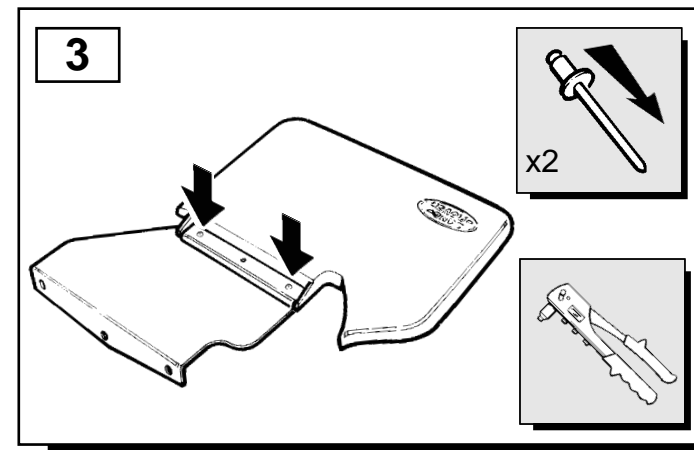
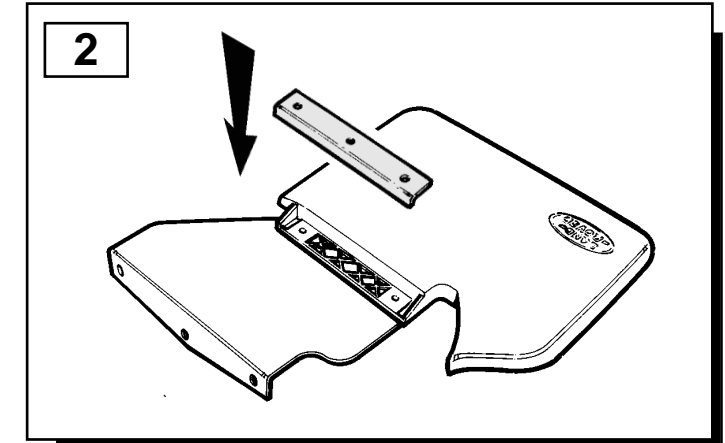
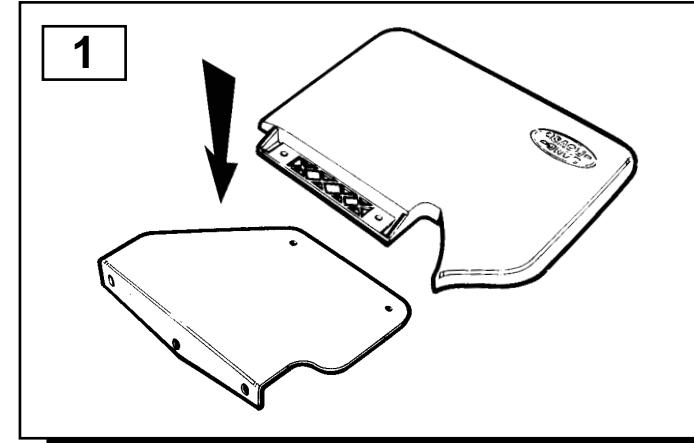

CLICK HERE TO **DOWNLOAD** THE COMPLETE MANUAL

- Thank you very much for reading the preview of the manual.
- You can download the complete manual from: www.heydownloads.com by clicking the link below



- Please note: If there is no response to CLICKING the link, please download this PDF first and then click on it.

CLICK HERE TO **DOWNLOAD** THE COMPLETE MANUAL

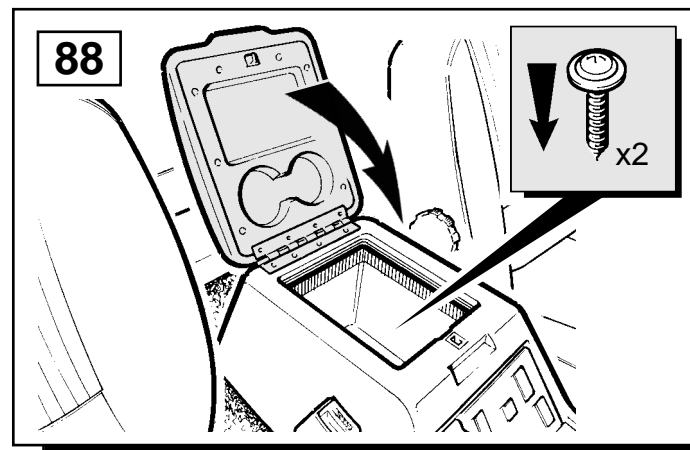
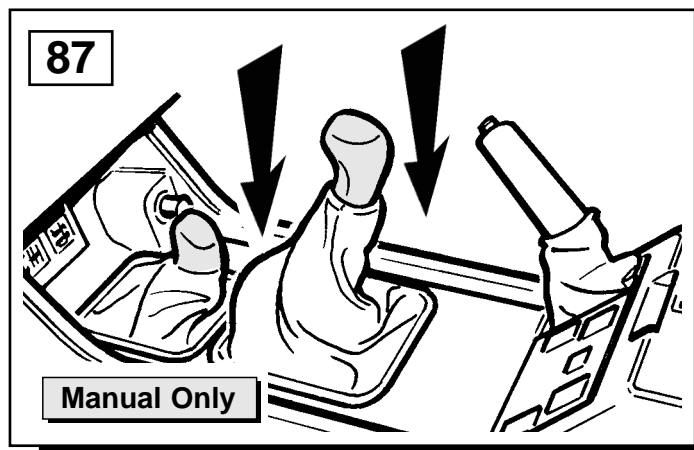
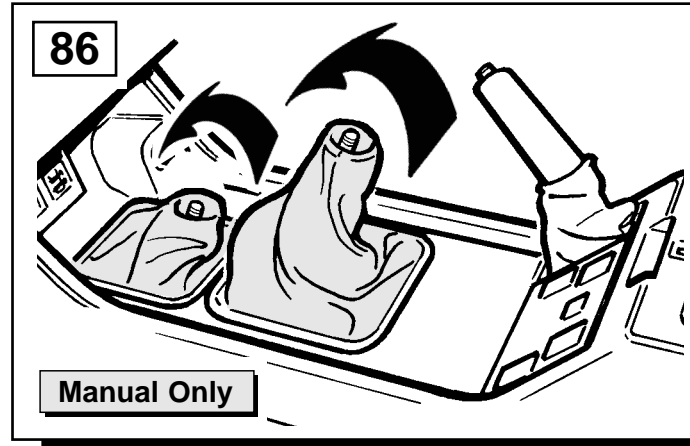
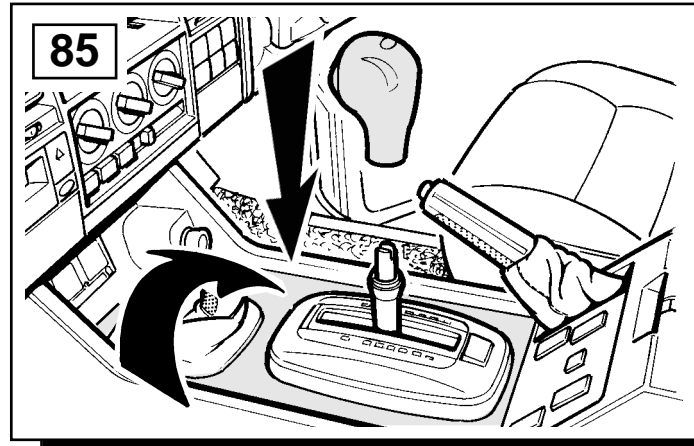

Navigation System Initialisation

Start the engine and keep running during the process.

Insert the map CD into the Navigation computer located under the seat.

Switch on the radio by pressing the **Vol/Power** button.

The System will display:

ACHTUNG!! Beachten Sie immer die gültigen Verkehrsregeln.



Press the **Push/Turn** button.

Press the **Nav Button**. Wait for the system to initialise (approximately 30 seconds).

Remove the Map CD and insert the software CD and confirm **OK** by pressing the **Push/Turn** button.

Wait for approximately 1 minute while the system performs a self-check. The software will then be loaded which will take approximately 2 minutes. When completed the CD will be ejected. Remove the CD and press the **Turn/Push** button.

Wait for the following menu:

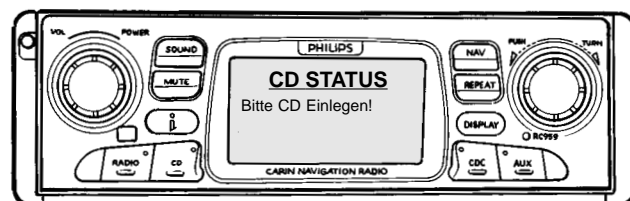

Insert the map CD into the Navigation computer and press the **Push/Turn** button.

Press the **Nav button**. Wait for the system to initialise (approximately 30 seconds) and select **“EINSTELLUNGEN”** from the menu by rotating the **Push/Turn** button until it is highlighted.

Push the **Push/Turn** Button, a new menu will be displayed.

Select **“SPRACHE”** from the menu by rotating the **Push/Turn** button until it is highlighted.

Push the **Turn/Push** button, the system will prompt you with:

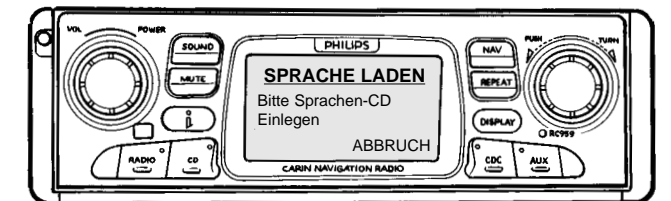

Eject the map CD and insert the software CD then press the **Push/Turn** Button.

Rotate the **Push/Turn** button until **“English Female Voice 1”** or **“2”** is highlighted.

Press **Push/Turn** Button.

The system will load the new language (approximately 2 minutes).

When load is complete the CD will eject. Remove the CD and press the **Push/Turn** button.

The system will re-boot. When prompted, insert the map CD and press the **Push/Turn** button.

To activate the steering wheel **Radio Remote** switches:

Press the **Radio** button.

Rotate the **Push/Turn** button until the Initialization is highlighted.

Press the **Push/Turn** button.

Rotate the **Push/Turn** button until **Le Mouse** is highlighted.

Press the **Push/Turn** button.

Press the **Radio** button.

Procedure Completed

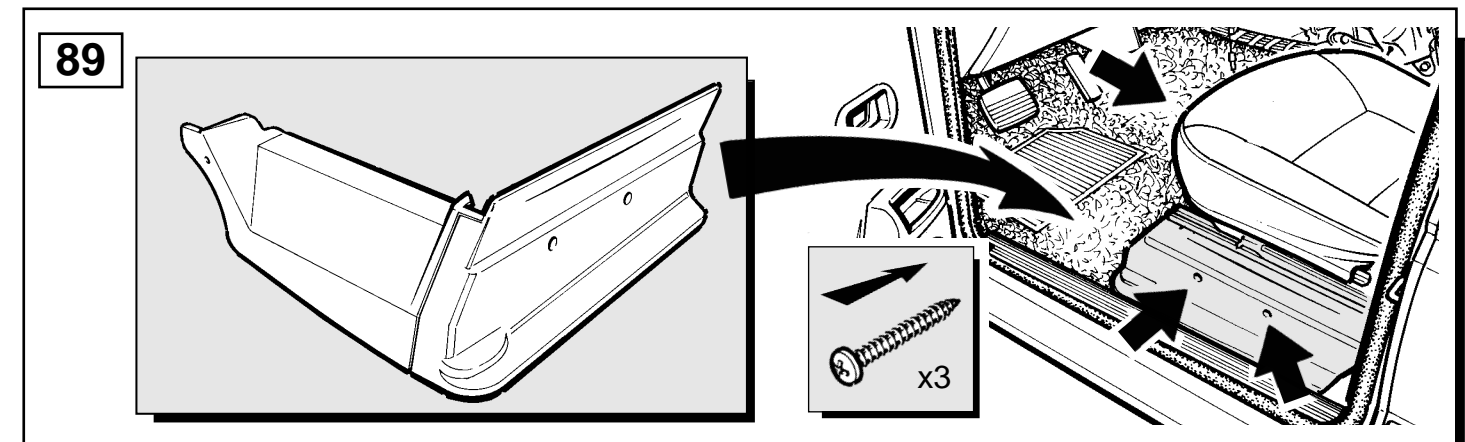

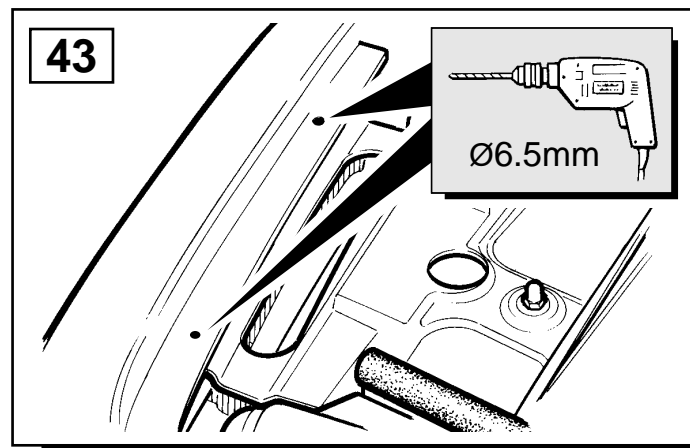
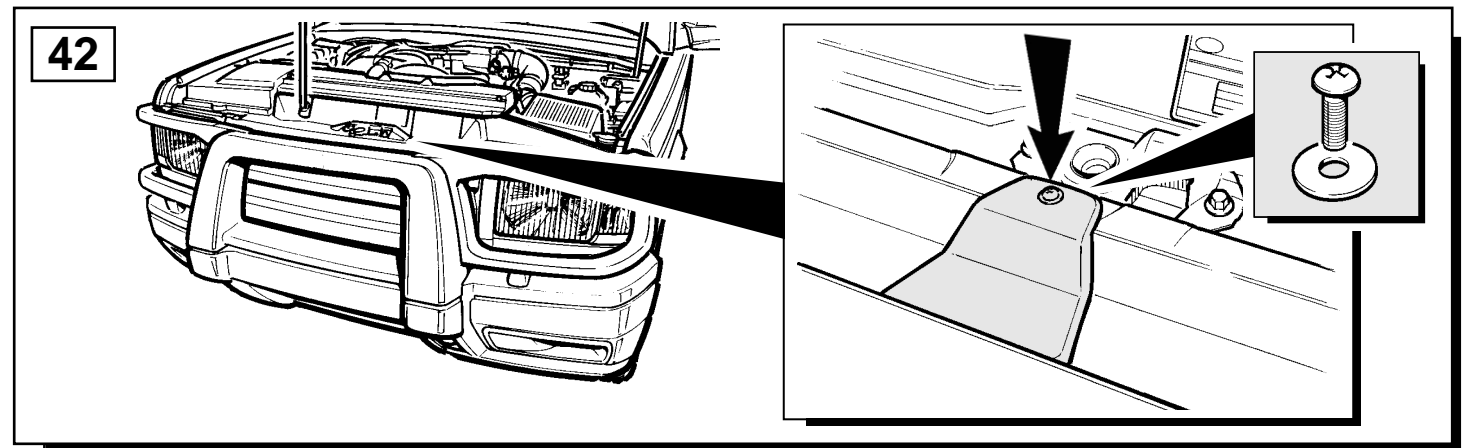
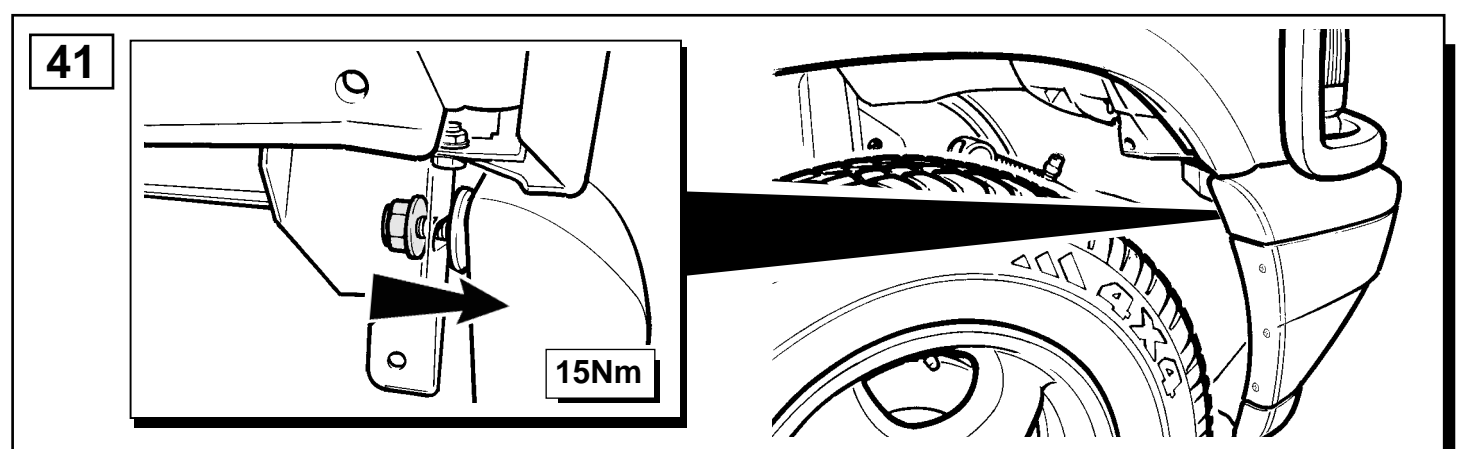
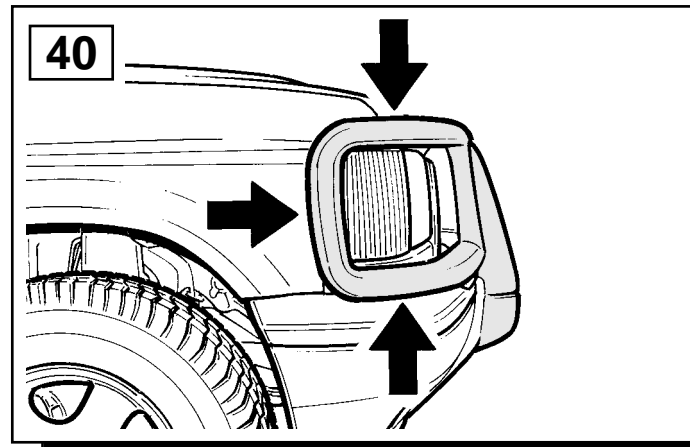
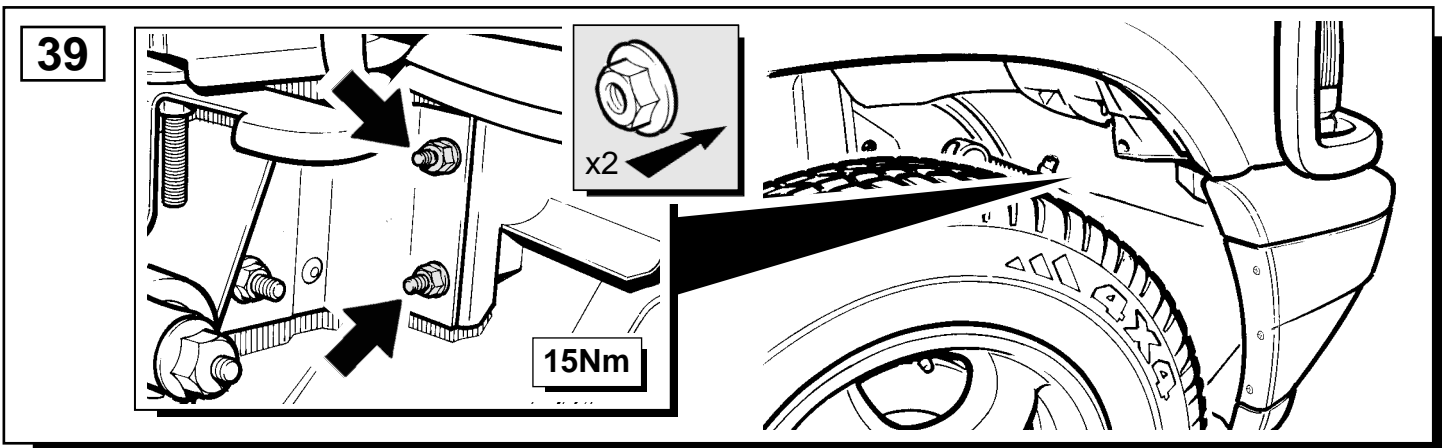
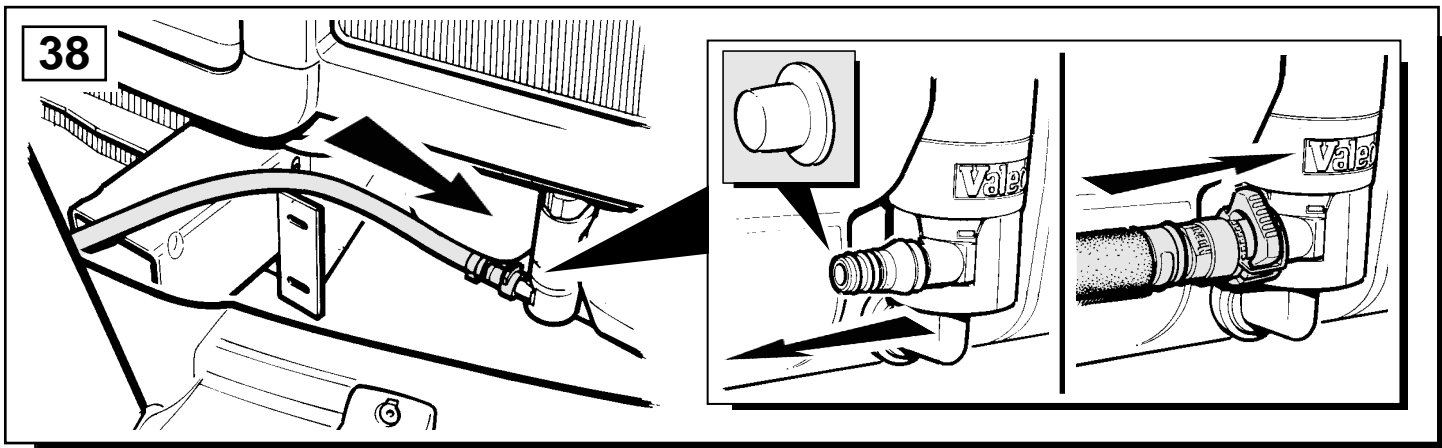
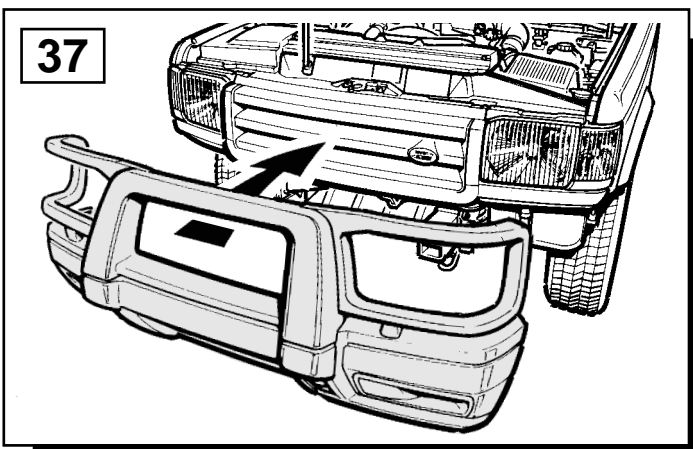
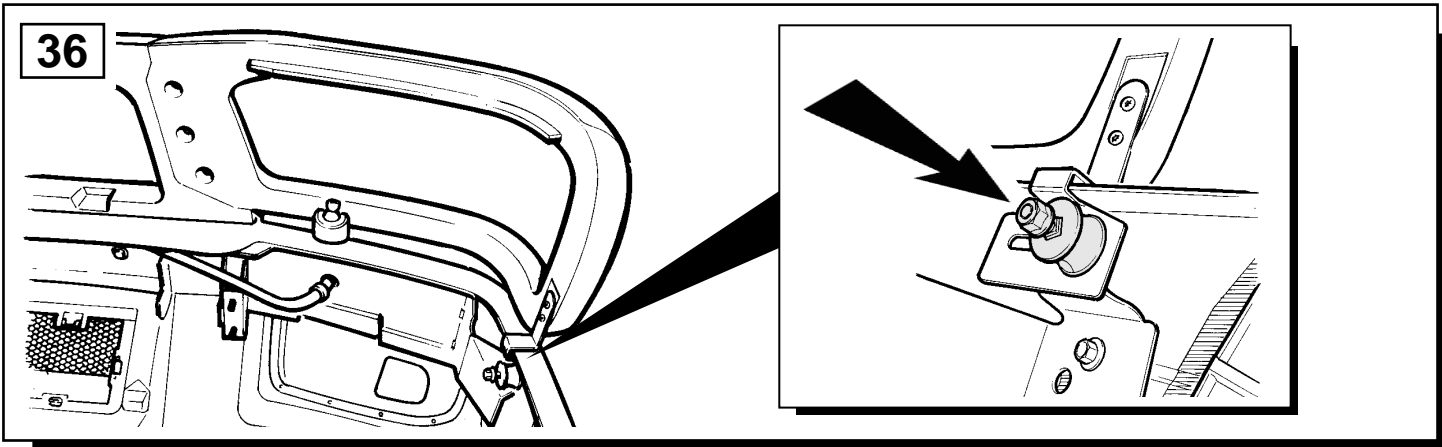



ACCESSORIES

WARNING

Accessories which are not properly fitted can be dangerous. Read the instructions carefully prior to fitting. Whilst fitting, comply with the instructions at all times. If in doubt, contact your nearest Land Rover Dealer.

ACHTUNG!

Nicht sachgemäß montiertes Zubehör kann gefährlich sein. Lesen Sie die Montageanleitung sorgfältig, bevor Sie das Teil montieren. Halten Sie sich bei der Montage an die Anleitung. Bei Unsicherheiten wenden Sie sich bitte an Ihren Land Rover Händler.

AVERTISSEMENT

Les accessoires qui ne sont pas correctement montés risquent d'être dangereux. Veuillez lire soigneusement les instructions avant d'effectuer la pose. Respectez toujours les instructions en cours de pose. En cas de doute, consultez votre concessionnaire Land Rover local.

AVISO

Aquellos accesorios que no hayan sido ajustados debidamente pueden resultar peligrosos. Lea las instrucciones detenidamente antes de iniciar el montaje. Durante el montaje siga las instrucciones en todo momento. En caso de duda póngase en contacto con su Concesionario de Land Rover.

AVVERTENZA

Gli accessori non sistemati come previsto possono essere pericolosi. Leggere attentamente le istruzioni prima del fissaggio. Durante il montaggio seguire sempre le relative istruzioni. In caso di dubbio rivolgersi al più vicino concessionario della Land Rover.

ADVERTÊNCIA!

Os Acessórios que não são montados adequadamente podem ser perigosos. Leia as instruções cuidadosamente antes de montar. Durante a montagem, obedeça as instruções todo o tempo. Se tiver alguma dúvida, contacte o Concessionário LandRover mais próximo.

WAARSHCUWING

Accessoires die niet op de juiste wijze zijn gemonteerd kunnen gevaar opleveren. Lees zorgvuldig de instructies alvorens met de montage te beginnen. Houd u tijdens de montage te allen tijde aan de instructies. Neem bij twijfel contact op met de dichtstbijzijnde Land Rover dealer.

ΠΡΟΕΙΔΟΠΟΙΗΣΗ

Τα προαιρετικά εξαρτήματα που δεν έχουν τοποθετηθεί σωστά μπορεί να είναι επικίνδυνα. Διαβάστε τις οδηγίες πριν προχωρήσετε στην τοποθέτησή τους. Κατά την τοποθέτηση, τηρείτε συνεχώς τις οδηγίες. Αν έχετε οποιαδήποτε αμφιβολία, επικοινωνήστε με τον πλησιέστερο αντιπρόσωπο της.

注意

正しく取り付けられていない備品があると、事故の原因になります。取付ける前にこのマニュアルをよくお読みください。取付けの際は必ずこのマニュアルにある指示に従ってください。何か不明な点がありましたら、お近くのランド・ローバー社のディーラーまでお問い合わせください。



FITTING INSTRUCTION

Sports Bars

EINBAUANLEITUNG

Dachreling

INSTRUCTION DE MONTAGE

Barres Sport

ISTRUZIONI PER L'USO

Barre Sportive

INSTRUCCION DE MONTAJE

Barras Deportivas

INSTRUÇÕES DE MONTAGEM

Barres de esporte

MONTAGEHANDLEIDING

Beschermingsbeugels

ΟΔΗΓΙΑ ΤΟΠΟΘΕΤΗΣΗΣ

Αγωνιστικές Μπάρες

取付用マニュアル
スポーツ用品ルーフキャリア

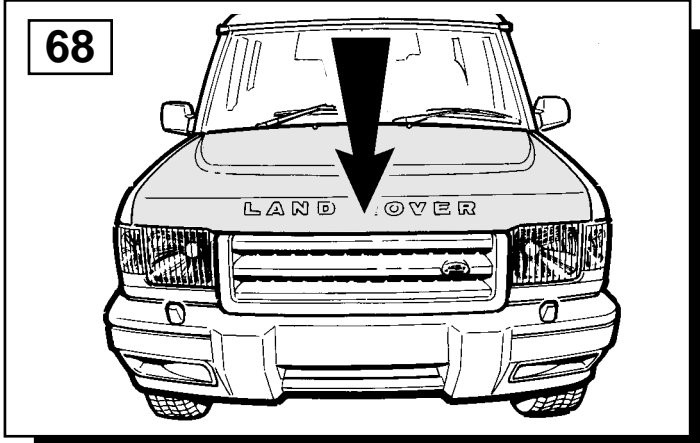
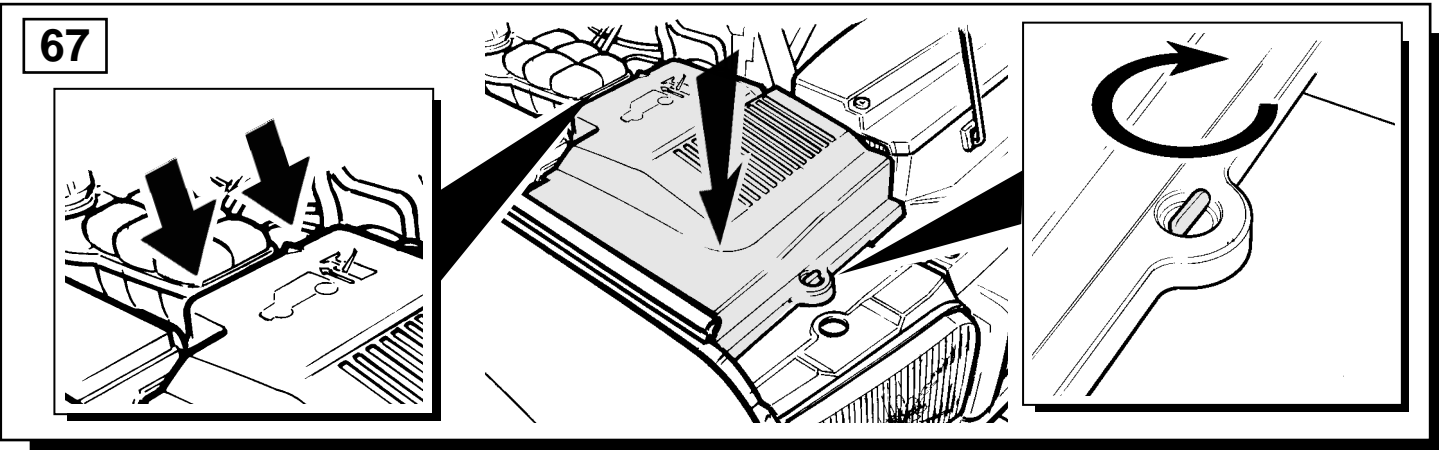

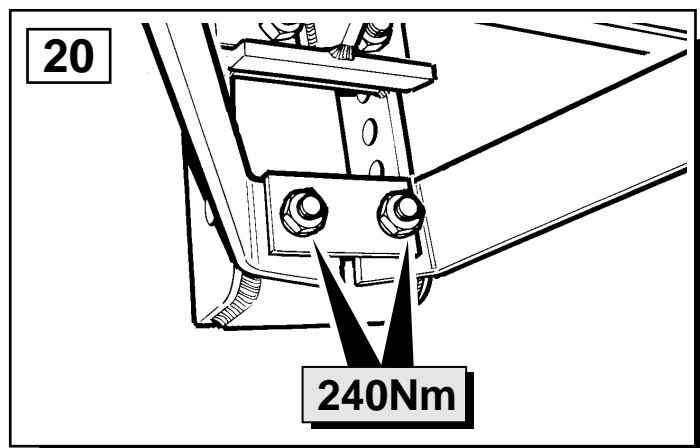
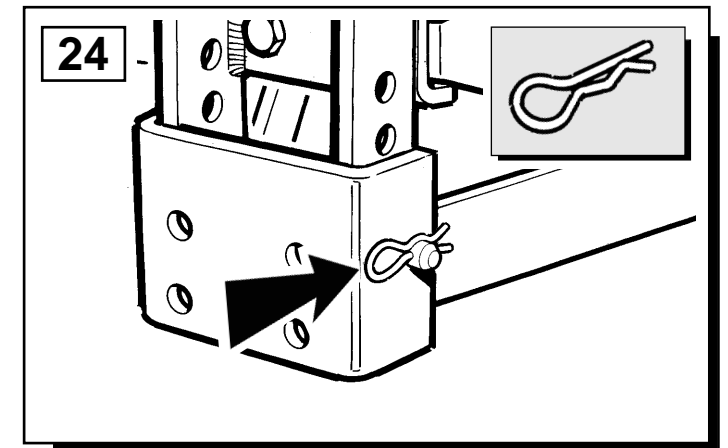
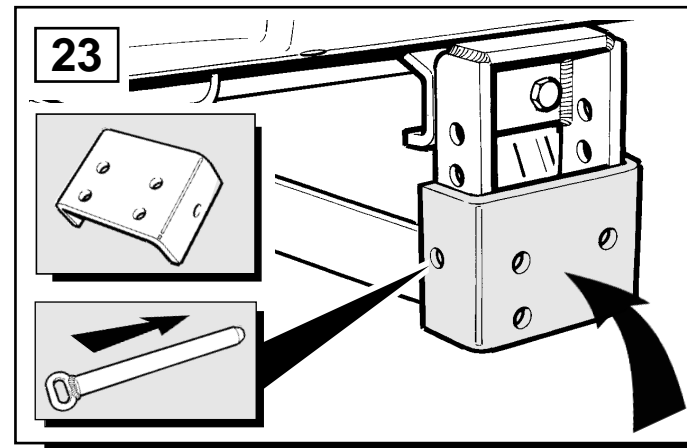
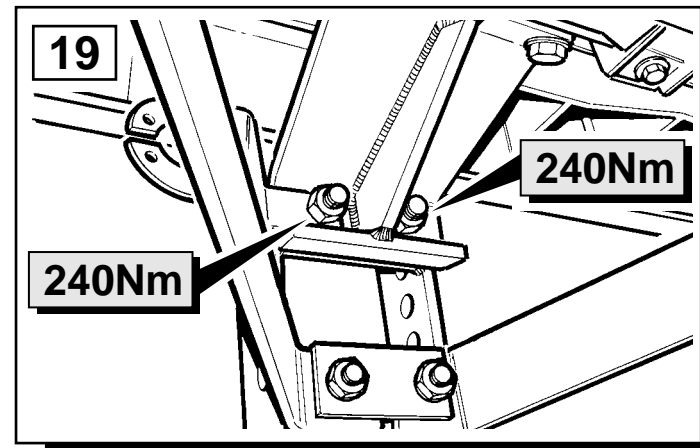
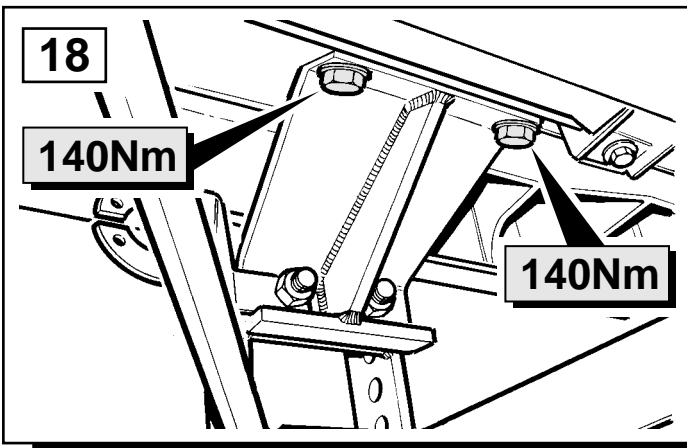
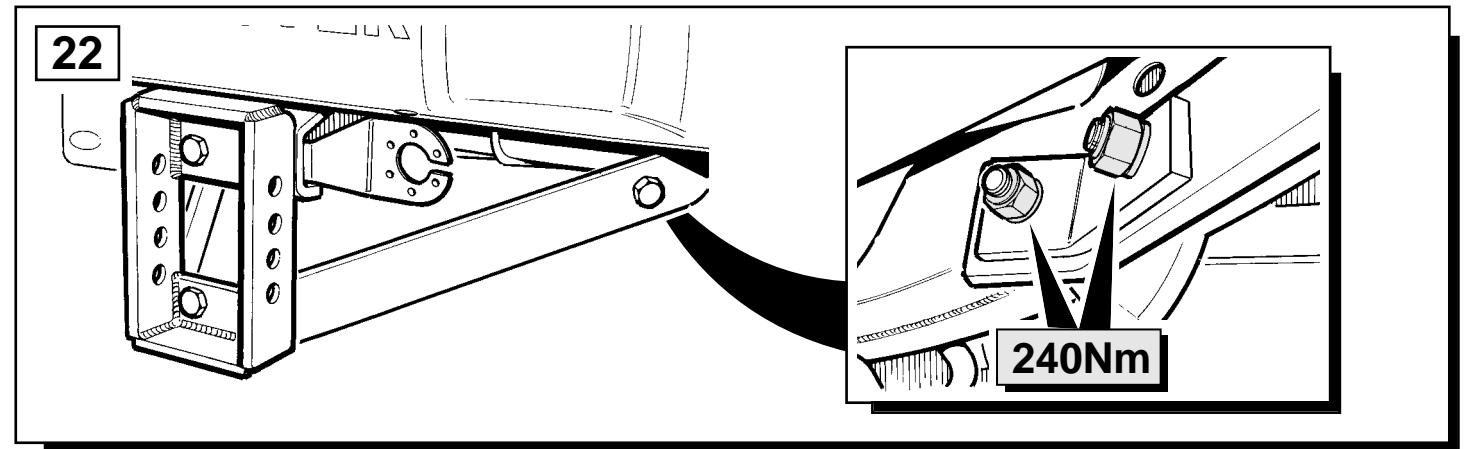
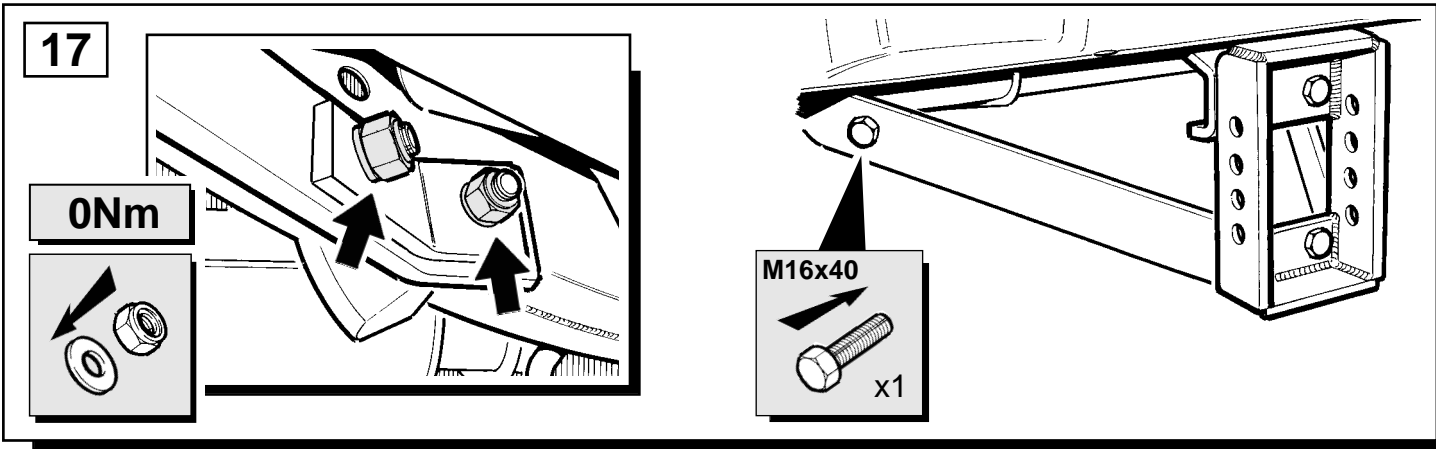
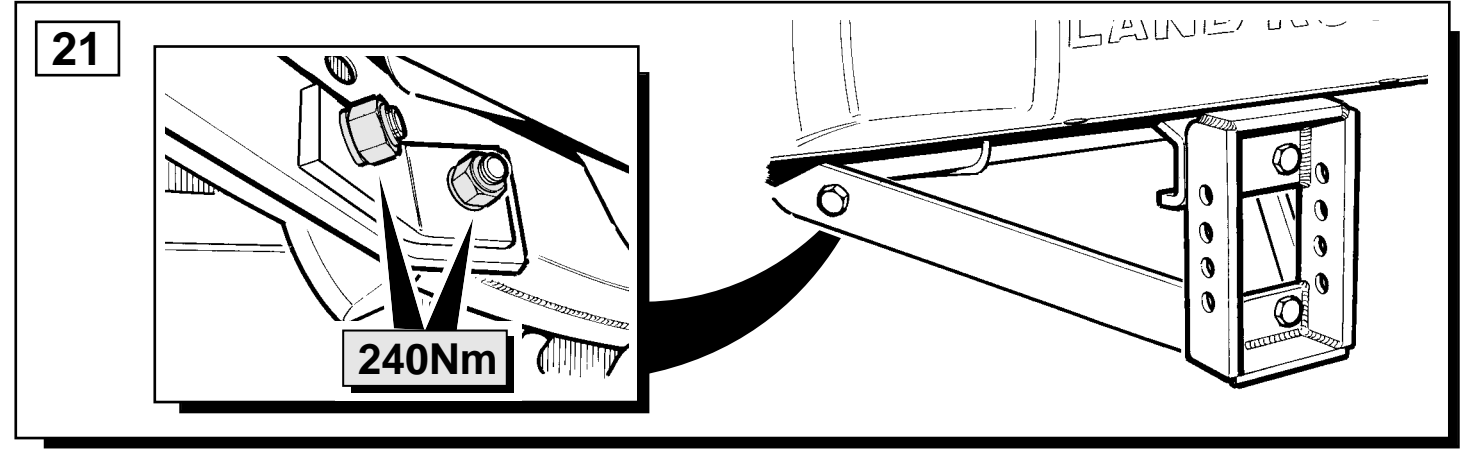
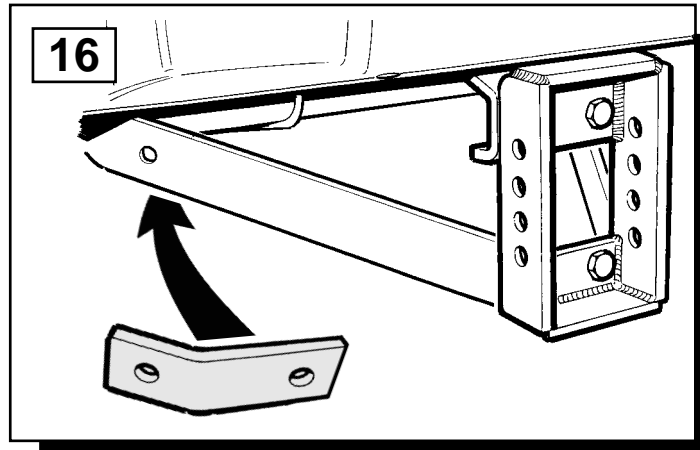

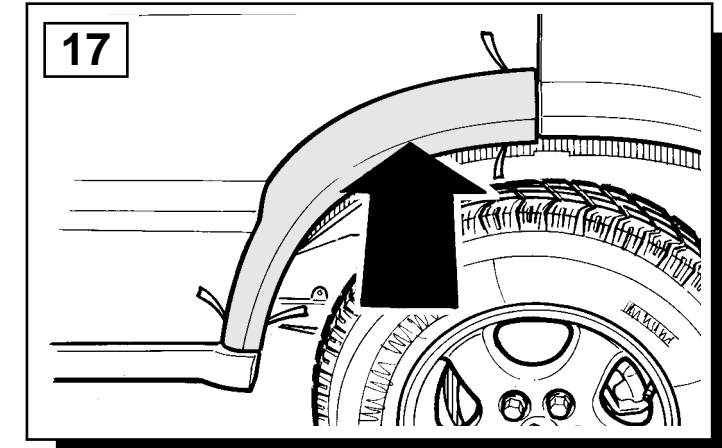
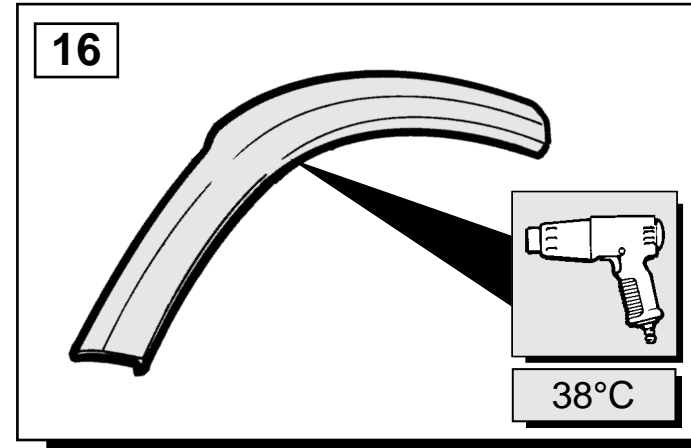
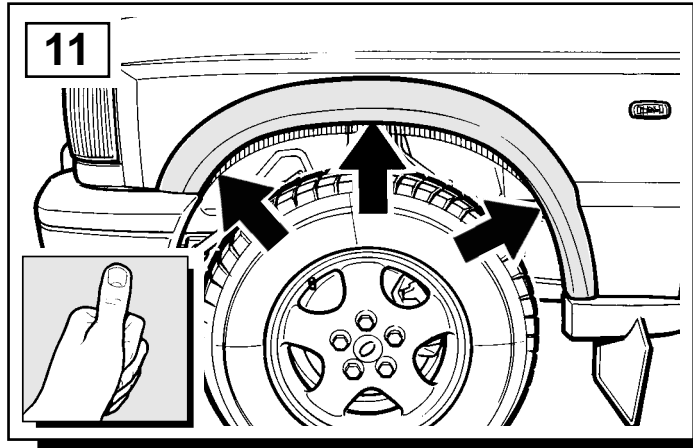

12

GB	Silicon remover/Grease remover	
D	Silikon-Entferner/Fett-Entferner	
F	Produit solvant des Silicones/Dissolvant	
I	Asporta-Silicone/Sgrassatore	
E	Eliminador de Silicona/Quitagrasas	
P	Removedor de silicone/Removedor de graxa	
NL	Siliconen verwijderaar/Ontvetter	
GR	Καθαριστικό για Σιλικάκη/Γράσο	
B	シリコン・リムーバー/オイル・リムーバー	

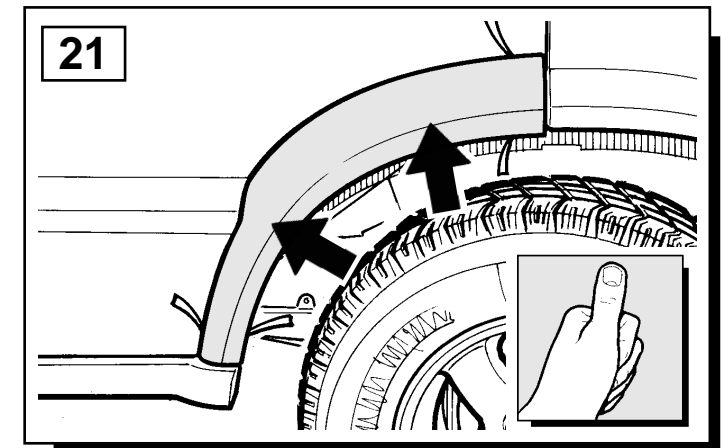
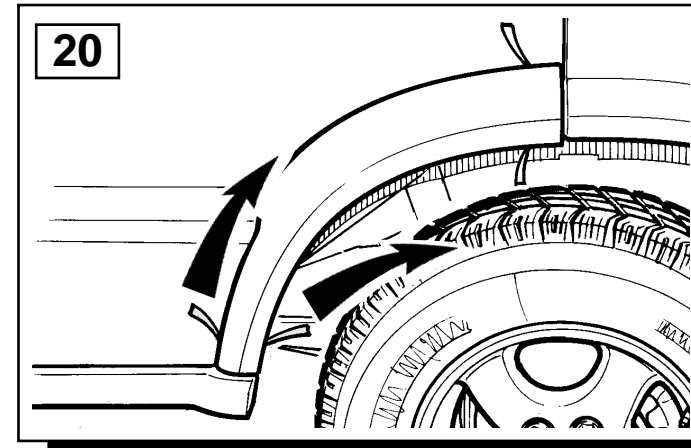
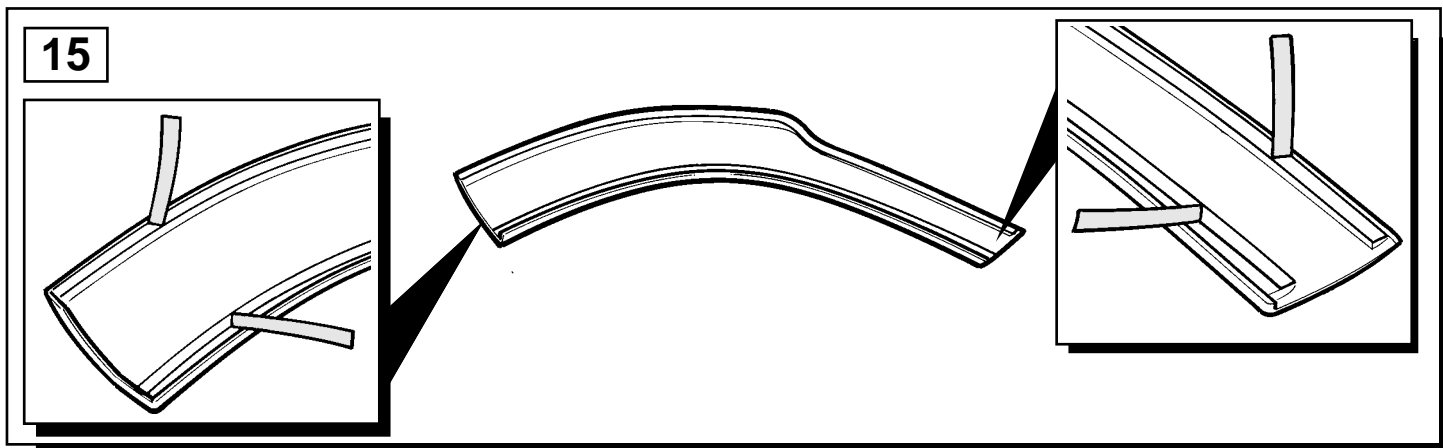
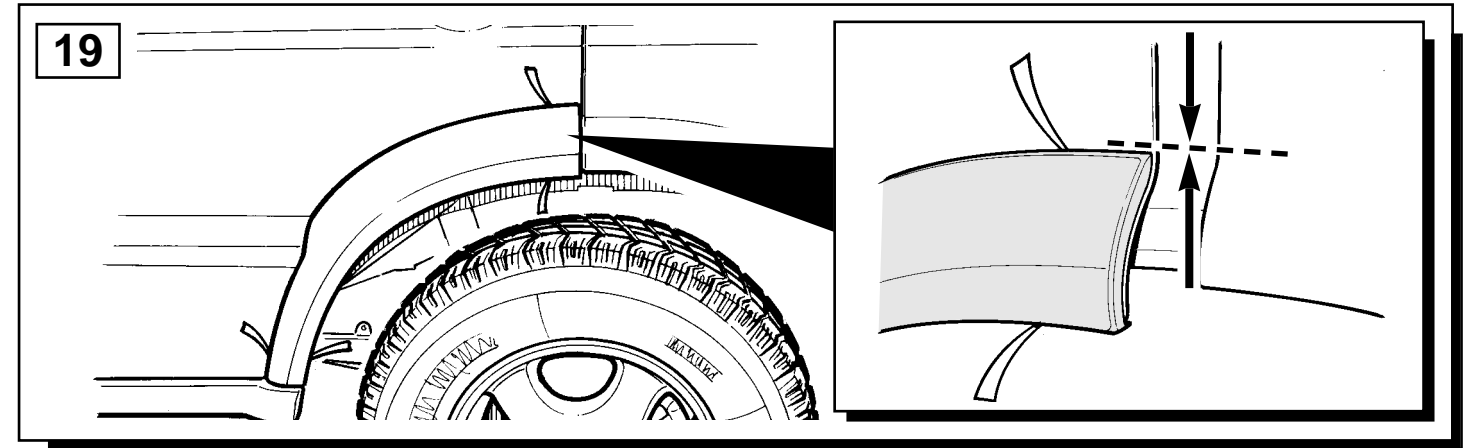
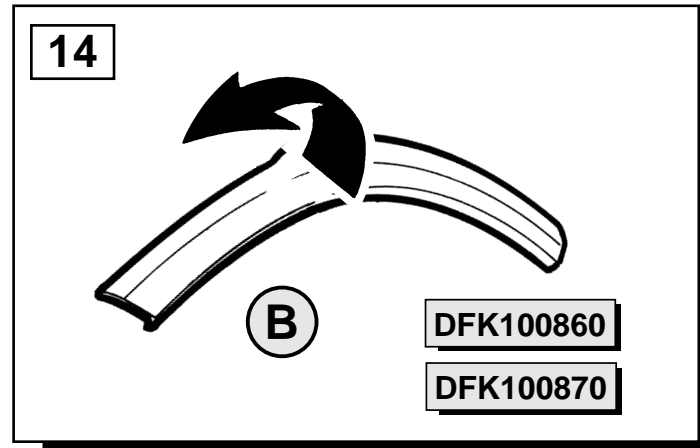
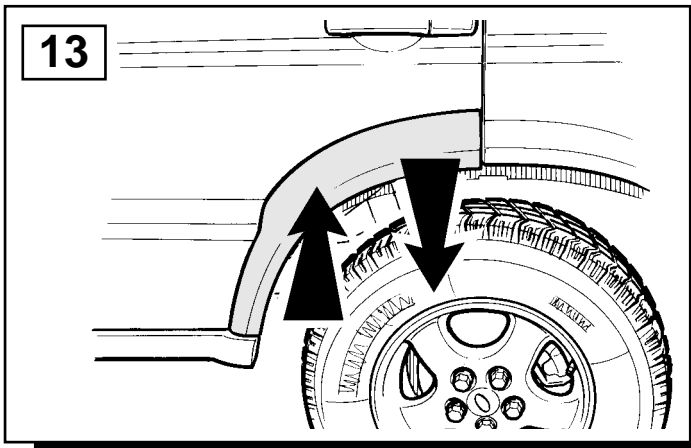
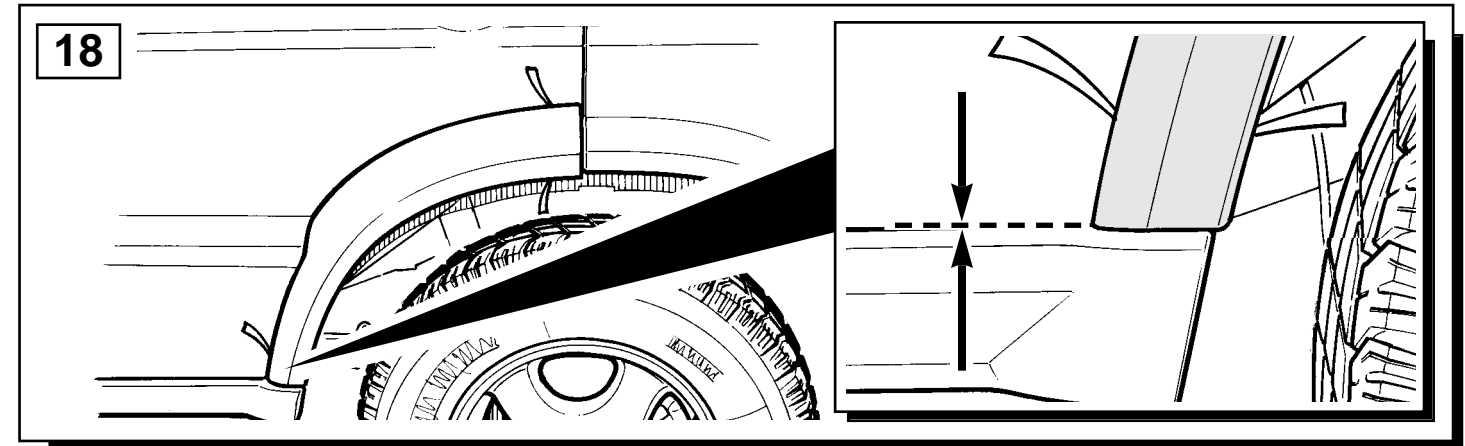

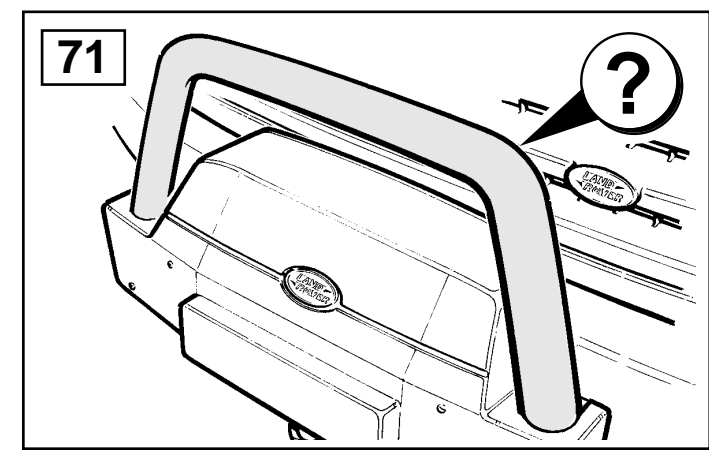
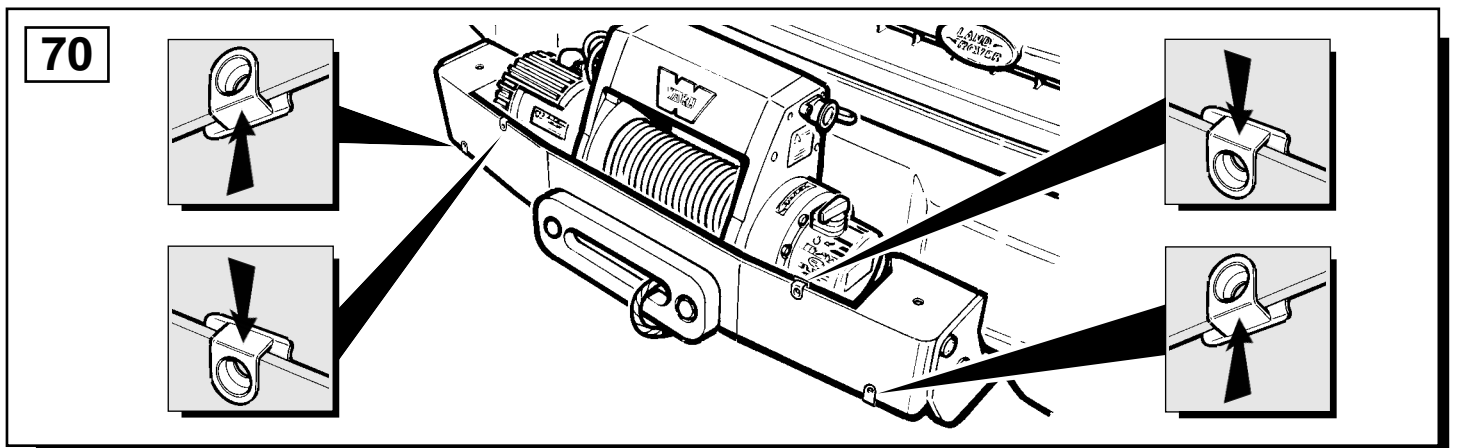
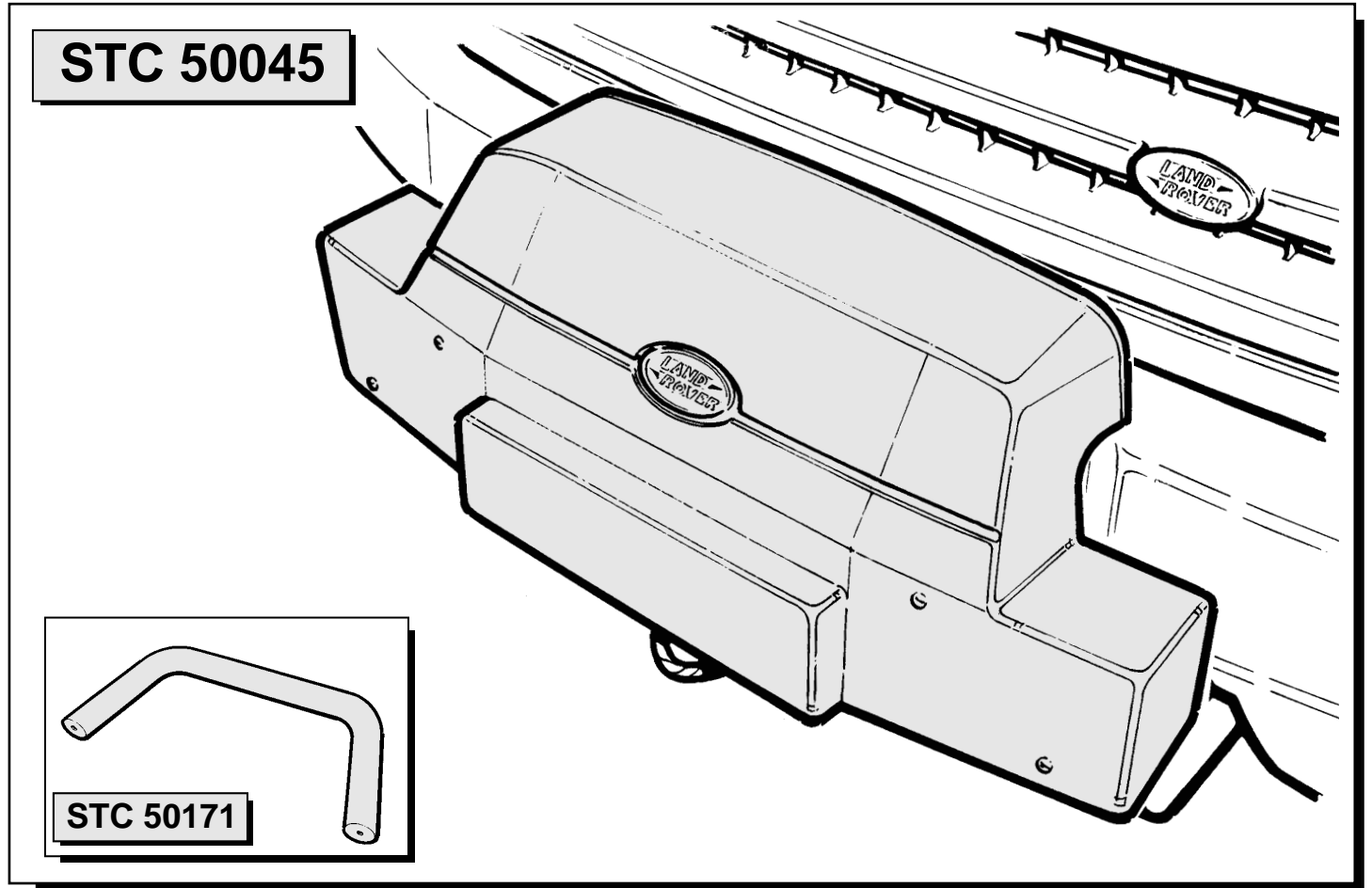
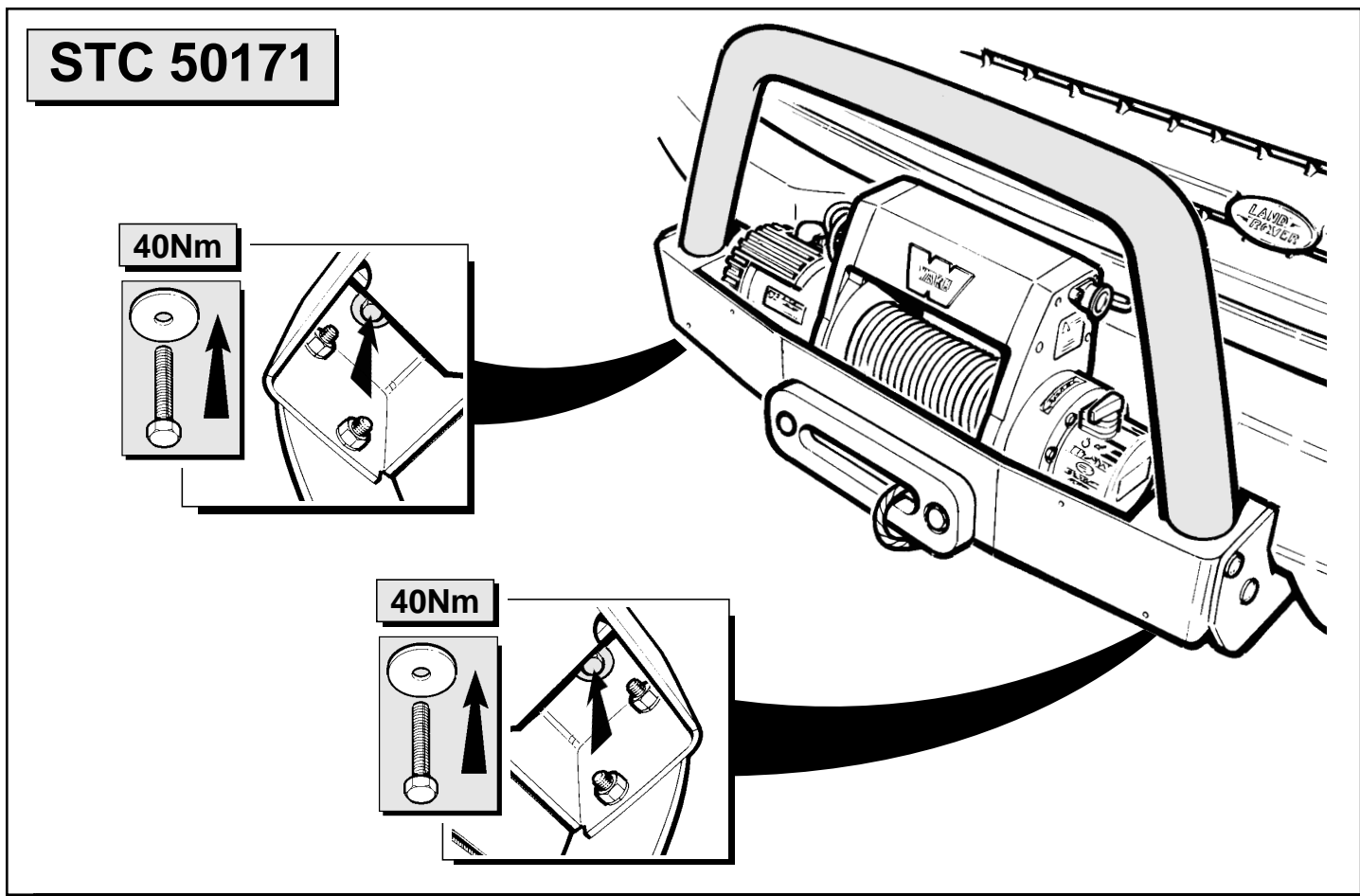
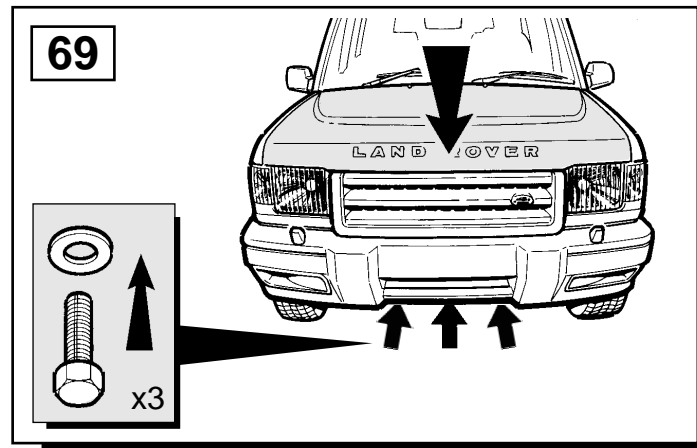
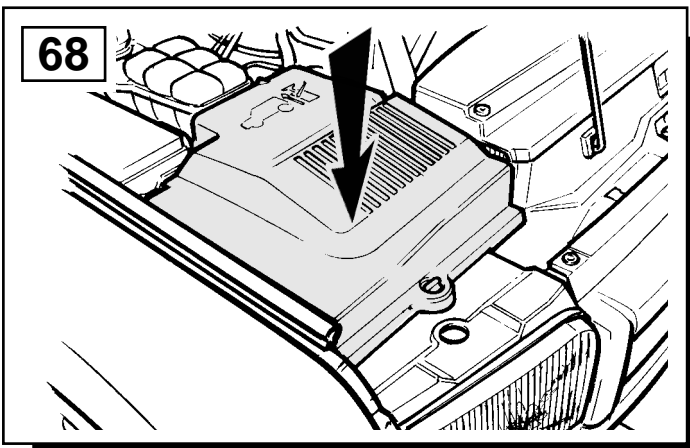
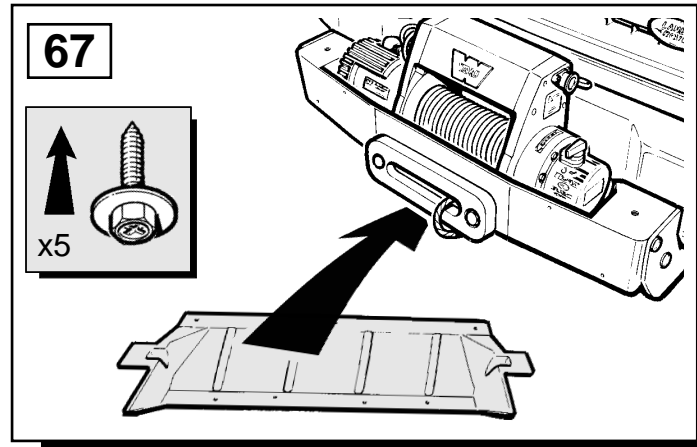
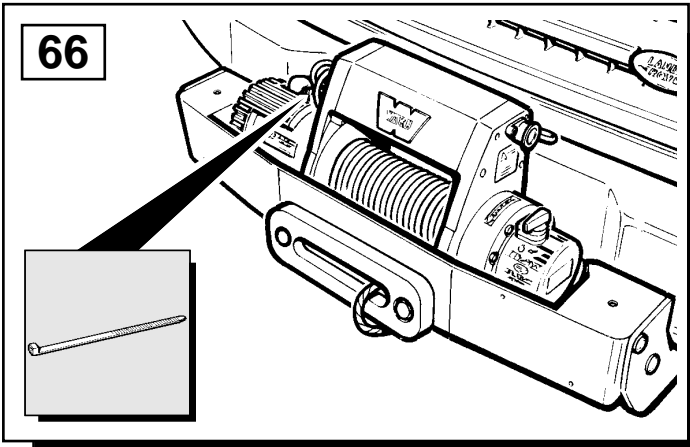



ACCESSORIES

WARNING

Accessories which are not properly fitted can be dangerous. Read the instructions carefully prior to fitting. Whilst fitting, comply with the instructions at all times. If in doubt, contact your nearest Land Rover Dealer.

ACHTUNG!

Nicht sachgemäß montiertes Zubehör kann gefährlich sein. Lesen Sie die Montageanleitung sorgfältig, bevor Sie das Teil montieren. Halten Sie sich bei der Montage an die Anleitung. Bei Unsicherheiten wenden Sie sich bitte an Ihren Land Rover Händler.

AVERTISSEMENT

Les accessoires qui ne sont pas correctement montés risquent d'être dangereux. Veuillez lire soigneusement les instructions avant d'effectuer la pose. Respectez toujours les instructions en cours de pose. En cas de doute, consultez votre concessionnaire Land Rover local.

AVISO

Aquellos accesorios que no hayan sido ajustados debidamente pueden resultar peligrosos. Lea las instrucciones detenidamente antes de iniciar el montaje. Durante el montaje siga las instrucciones en todo momento. En caso de duda póngase en contacto con su Concesionario de Land Rover.

AVVERTENZA

Gli accessori non sistemati come previsto possono essere pericolosi. Leggere attentamente le istruzioni prima del fissaggio. Durante il montaggio seguire sempre le relative istruzioni. In caso di dubbio rivolgersi al più vicino concessionario della Land Rover.

ADVERTÊNCIA!

Os Acessórios que não são montados adequadamente podem ser perigosos. Leia as instruções cuidadosamente antes de montar. Durante a montagem, obedeça as instruções todo o tempo. Se tiver alguma dúvida, contacte o Concessionário LandRover mais próximo.

WAARSHCUWING

Accessoires die niet op de juiste wijze zijn gemonteerd kunnen gevaar opleveren. Lees zorgvuldig de instructies alvorens met de montage te beginnen. Houd u tijdens de montage te allen tijde aan de instructies. Neem bij twijfel contact op met de dichtstbijzijnde Land Rover dealer.

ΠΡΟΕΙΔΟΠΟΙΗΣΗ

Τα προαιρετικά εξαρτήματα που δεν έχουν τοποθετηθεί σωστά μπορεί να είναι επικίνδυνα. Διαβάστε τις οδηγίες πριν προχωρήσετε στην τοποθέτησή τους. Κατά την τοποθέτηση, τηρείτε συνεχώς τις οδηγίες. Αν έχετε οποιαδήποτε αμφιβολία, επικοινωνήστε με τον πλησιέστερο αντιπρόσωπο της.

注意

正しく取り付けられていない備品があると、事故の原因になります。取付ける前にこのマニュアルをよくお読みください。取付けの際は必ずこのマニュアルにある指示に従ってください。何か不明な点がありましたら、お近くのランド・ローバー社のディーラーまでお問い合わせください。



FITTING INSTRUCTION

Roof Rack

EINBAUANLEITUNG

Dachgepäckträger

INSTRUCTION DE MONTAGE

Galerie de toit

ISTRUZIONI PER L'USO

Portabagagli per tetto

INSTRUCCION DE MONTAJE

Baca

INSTRUÇÕES DE MONTAGEM

Bagageiro de Teto

MONTAGEHANDLEIDING

Dakimperiaal

ΟΔΗΓΙΑ ΤΟΠΟΘΕΤΗΣΗΣ

Σχάρα Οροφής

取付用マニュアル

ルーフキャリア



LAND ROVER ACCESSORIES

STC 50013 CHILD SAFETY SEAT

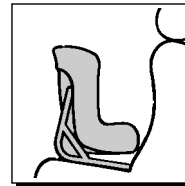

REARWARD FACING

Suitable for infants weighing less than 10kg (20lbs)
i.e. approximately 9 months.

IMPORTANT TO NOT USE FORWARD FACING BEFORE THE CHILD'S WEIGHT EXCEEDS 9KG

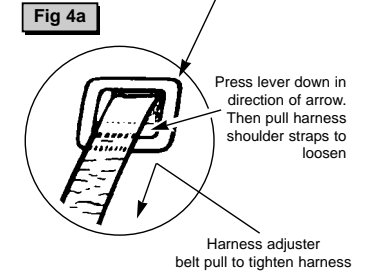
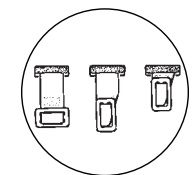
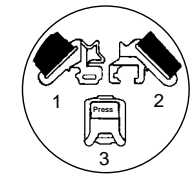
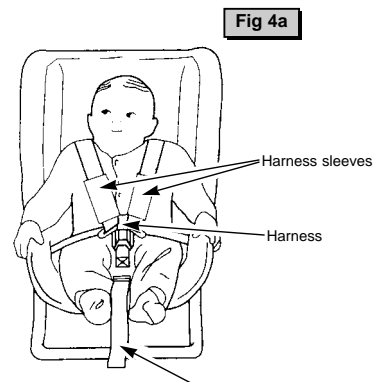
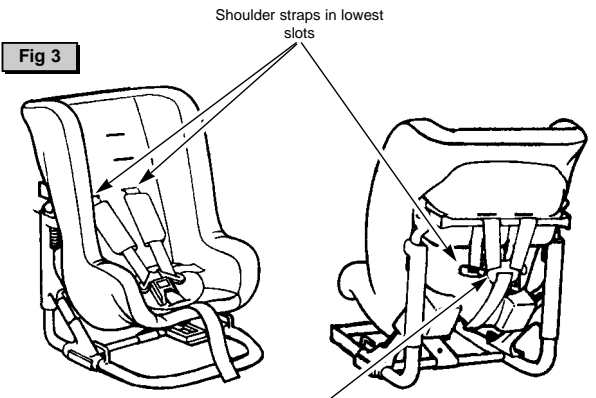
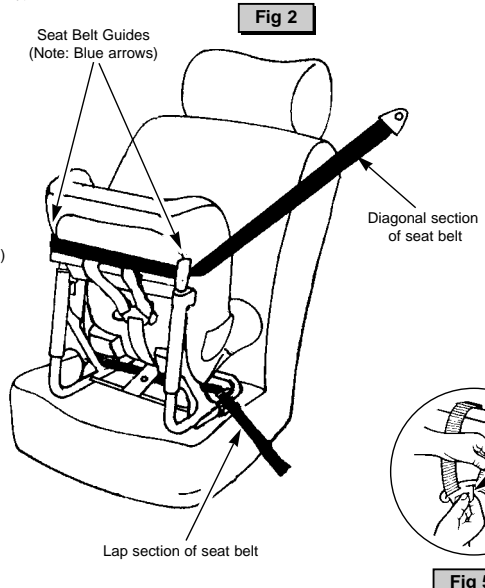
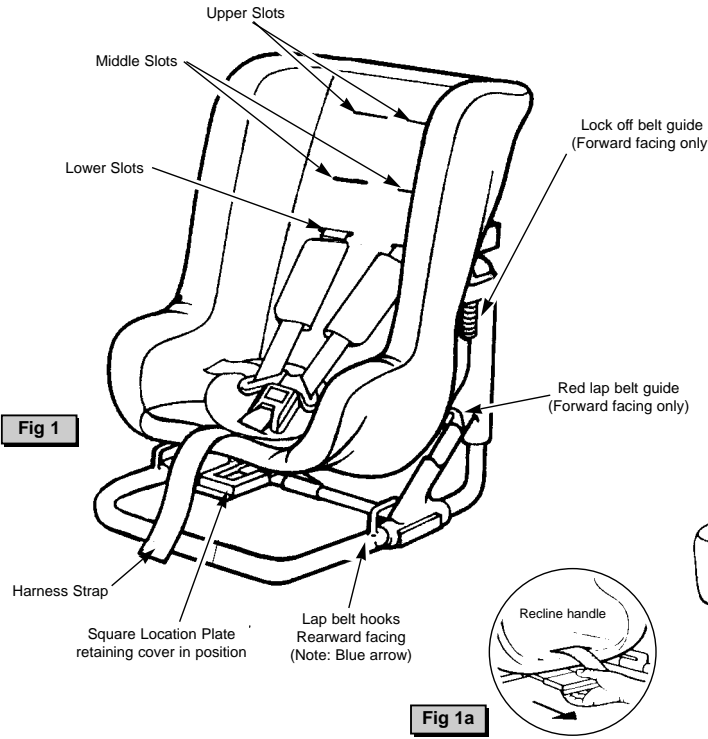

EXTREME HAZARD - DO NOT USE THE CHILD SAFETY SEAT IN PASSENGER SEATS EQUIPPED WITH AIRBAGS

- WARNINGS:**
- The Child Safety Seat must be fitted and used in accordance with the manufacturers instructions. An incorrect installation could be dangerous.
 - Car interiors can become very hot when left standing in direct sunlight and metal fittings on the seat and harness may become hot. It is therefore recommended that fittings that come into contact with the child are covered when the car is left standing in direct sunlight.
 - Seat and harness assemblies which get damaged or become badly worn or which have been involved in a serious accident must be replaced to maintain safety.
 - Do not place heavy objects on the parcel shelf which could, in the event of an accident, cause injury to passengers. Secure all loose luggage and sharp objects for the same purpose.
 - If you travel with passengers using the front and rear restraints, the lighter occupants should be in the rear seats and the heavier occupants in the front.
 - In the event of an emergency it is important that the child can be released quickly as defined by Regulations. This means that the buckle is not fully tamper proof and therefore your child should be persuaded not to play with the buckle when in use.
 - Ensure that no part of the child seat is trapped in a door or folding seat. If your vehicle has a folding seat ensure that it is correctly locked upright.
 - Under no circumstances should the harness be removed from the seat for use as a separate item.
 - Do not add to or modify this product in any way without prior consultation with the manufacturer, to do so could be dangerous.
 - Should your vision be restricted due to your personal preference of driving position using the Child Safety Seat in the rearward facing position in the front of the vehicle, we then recommend you install the Child Safety Seat in the rear of the vehicle, rearward facing.
 - A child must NEVER be left unattended while restrained in or out of the vehicle.

AN INCORRECT INSTALLATION COULD BE DANGEROUS SO PLEASE READ THESE FITTING INSTRUCTIONS CAREFULLY BEFORE COMMENCING INSTALLATION

- Fitting Instructions**
- Only suitable for use in vehicles fitted with 3-point safety belts approved to ECE regulation No.16 or other equivalent standards. Do not fit this child seat rearward facing using an adult lap belt.
- Installation of your Child Safety Seat rearward facing.**
- Adjust the seat to its reclined position and place the Child Safety Seat in the car facing the rear with the seat front edge against the car seat backrest. Take the adult 3-point seat belt and thread the lap section through the lap belt hooks, (blue arrows) see Fig 2. Make sure that the top section of the seat belt is not twisted and remove all slack from this section of the belt before continuing. Connect the seat belt tongue with the buckle, then pass the diagonal section of the seat belt through the gaps between the seat moulding and seat belt guides, (blue arrows) see Fig 2. Now push the child seat downwards (using your body weight if necessary) and pull the diagonal webbing as tight as possible, ensuring there is no slack in any part of the seat belt. **REMEMBER to check that your child seat is secure before every journey.**
- Removal of your Child Safety Seat.**
- To remove the seat, release the adult buckle and remove the belt from the frame. Lift the seat clear of the car.
- Occasional Adjustment of harness to suit height of child.**
- With the child seat in the rearward facing position the harness should be fitted to the LOWER slots in the seat shell (see Fig 3).
- Adjusting The Harness.**
- Ensure the shoulder straps are threaded in the correct slots for the size of the child. Sit your child in the seat and fasten the buckle over the child by aligning the two shoulder strap tongues numbered (1) and (2) and press firmly into the main buckle numbered (3), (see Fig 5a).
 - The lap straps of the harness should be kept as low as possible on the hips so as to firmly hold the pelvis. **NEVER** towards the stomach! To tighten, ensure that the straps are not twisted, pull at the end of the harness adjuster belt until the harness fit firmly around the child's body. Finally, pull both harness sleeves down from your child's shoulders onto the chest (Fig 4). **Remember the harness sleeves are an important safety feature - NEVER use the Child Safety Seat without them.**
 - To loosen the harness, press the lever inclining it forward in the direction of the arrow and pull the shoulder straps with your other hand, (Fig 4a).
 - Ensure that none of the harness webbing is twisted, particularly the lap and shoulder straps.
- Reclining the Child Safety Seat**
- To adjust the Child Safety Seat from the upright to the reclined position - lift the recline handle and pull the base of the seat moulding towards you until the locking mechanism engages (Fig 1a). When the seat is rearward facing it must only be used in the fully reclined position.
 - To adjust from the reclined position back to the upright position - lift the recline handle and gently lower the seat moulding until the locking mechanism engages. **ALWAYS ENSURE THAT THE LOCKING MECHANISM IS FULLY ENGAGED.**
- Emergency release**
- In the event of an emergency the child should be removed from the seat by pressing the red button on the harness buckle (Fig 5a).
- Cleaning**
- To clean harness, harness sleeves and seat, use mild soap and warm water. Do not use: detergent, bleach or dye, which may weaken the stitching or webbing.
 - To clean the cover - remove the cover as follows and follow the washing instructions label:
 - Open buckle and remove from seat by passing the metal retainer which is attached to the end of the crotch strap; through the slot in the base of the seat, then through the slot in the cover, now pass each strap of harness through the slot in the shell and cover, having first removed other end from yoke (Fig 5).
 - Remove harness sleeves by gently easing them through their slots (Fig 5b).
 - Release retaining elastic loops at the bottom rear of plastic seat shell. Now, peel cover from edge of seat and square location plate, situated by the harness adjuster (Fig 1).
 - To refit the cover simply reverse these instructions, make sure there are no twists in the harness and **REMEMBER** to re-fit the harness sleeves.
- APPROVED TO EUROPEAN REGULATION
ECE R44.03 GROUPS 0 AND 1
- UNIVERSAL
Less than 10kgY
- E11
03 44 070



ACCESSORIES

WARNING

Accessories which are not properly fitted can be dangerous. Read the instructions carefully prior to fitting. Whilst fitting, comply with the instructions at all times. If in doubt, contact your nearest Land Rover Dealer.

ACHTUNG!

Nicht sachgemäß montiertes Zubehör kann gefährlich sein. Lesen Sie die Montageanleitung sorgfältig, bevor Sie das Teil montieren. Halten Sie sich bei der Montage an die Anleitung. Bei Unsicherheiten wenden Sie sich bitte an Ihren Land Rover Händler.

AVERTISSEMENT

Les accessoires qui ne sont pas correctement montés risquent d'être dangereux. Veuillez lire soigneusement les instructions avant d'effectuer la pose. Respectez toujours les instructions en cours de pose. En cas de doute, consultez votre concessionnaire Land Rover local.

AVVERTENZA

Gli accessori non sistemati come previsto possono essere pericolosi. Leggere attentamente le istruzioni prima del fissaggio. Durante il montaggio seguire sempre le relative istruzioni. In caso di dubbio rivolgersi al più vicino concessionario della Land Rover.

AVISO

Aquellos accesorios que no hayan sido ajustados debidamente pueden resultar peligrosos. Lea las instrucciones detenidamente antes de iniciar el montaje. Durante el montaje siga las instrucciones en todo momento. En caso de duda póngase en contacto con su Concesionario de Land Rover.

ADVERTÊNCIA!

Os Acessórios que não são montados adequadamente podem ser perigosos. Leia as instruções cuidadosamente antes de montar. Durante a montagem, obedeça as instruções todo o tempo. Se tiver alguma dúvida, contacte o Concessionário LandRover mais próximo.

WAARSHCUWING

Accessoires die niet op de juiste wijze zijn gemonteerd kunnen gevaar opleveren. Lees zorgvuldig de instructies alvorens met de montage te beginnen. Houd u tijdens de montage te allen tijde aan de instructies. Neem bij twijfel contact op met de dichtstbijzijnde Land Rover dealer.

ΠΡΟΕΙΔΟΠΟΙΗΣΗ

Τα προαιρετικά εξαρτήματα που δεν έχουν τοποθετηθεί σωστά μπορεί να είναι επικίνδυνα. Διαβάστε τις οδηγίες πριν προχωρήσετε στην τοποθέτησή τους. Κατά την τοποθέτηση, τηρείτε συνεχώς τις οδηγίες. Αν έχετε οποιαδήποτε αμφιβολία, επικοινωνήστε με τον πλησιέστερο αντιπρόσωπο της.

注意

正しく取り付けられていない備品があると、事故の原因になります。取付ける前にこのマニュアルをよくお読みください。取付けの際は必ずこのマニュアルにある指示に従ってください。何か不明な点がありましたら、お近くのランド・ローバー社のディーラーまでお問い合わせください。



FITTING INSTRUCTION

Ski Box

EINBAUANLEITUNG

Skibox

INSTRUCTION DE MONTAGE

Coffret à skis

ISTRUZIONI PER L'USO

Cassa per sci

INSTRUCCIONES DE MONTAJE

Caja para esquíes

INSTRUÇÕES DE MONTAGEM

Mala para Esquis

MONTAGEHANDLEIDING

Ski-box

ΟΔΗΓΙΑ ΤΟΠΟΘΕΤΗΣΗΣ

Κιβώτιο για τη Μεταφορά των Σκι

取付用マニュアル

スキーボックス

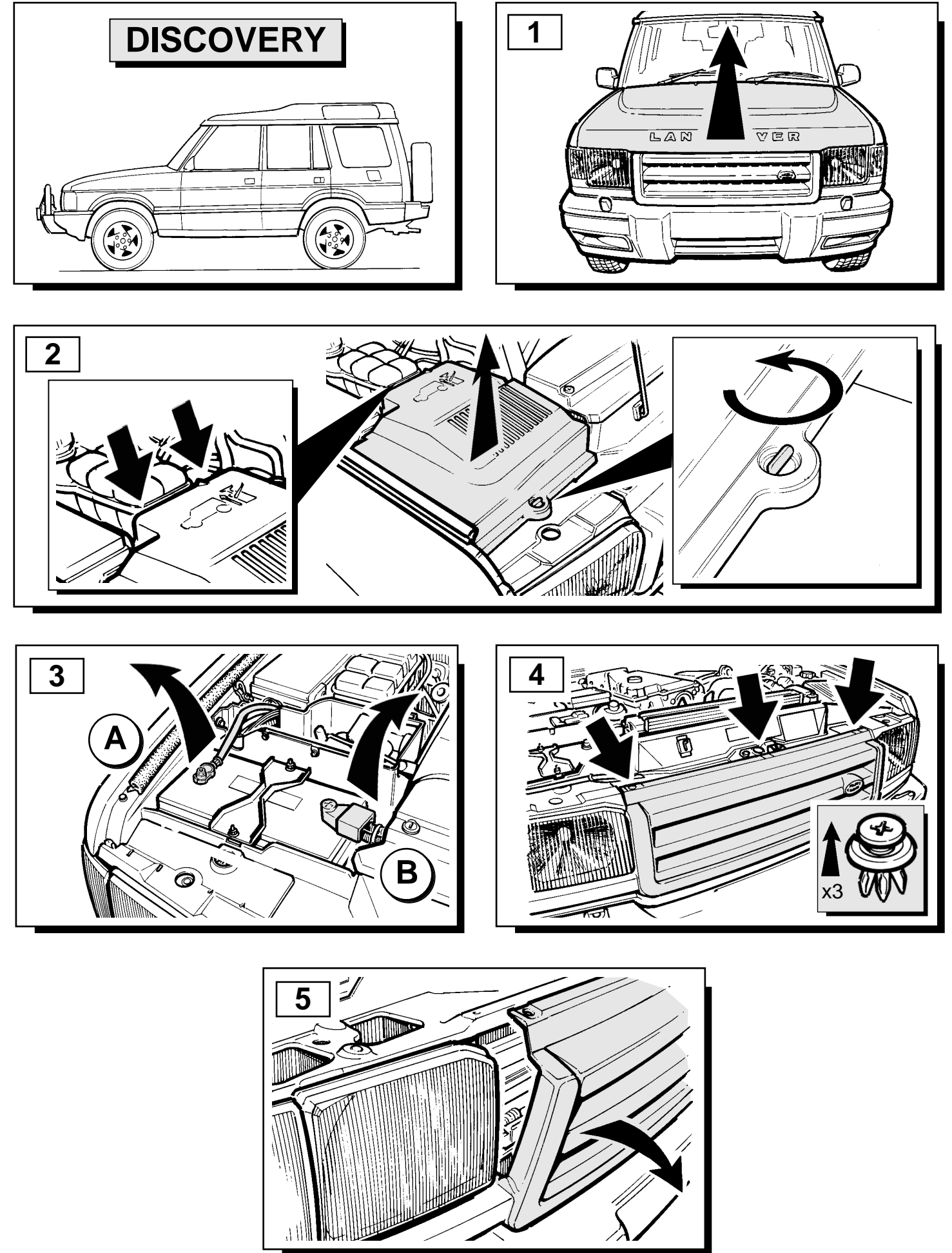
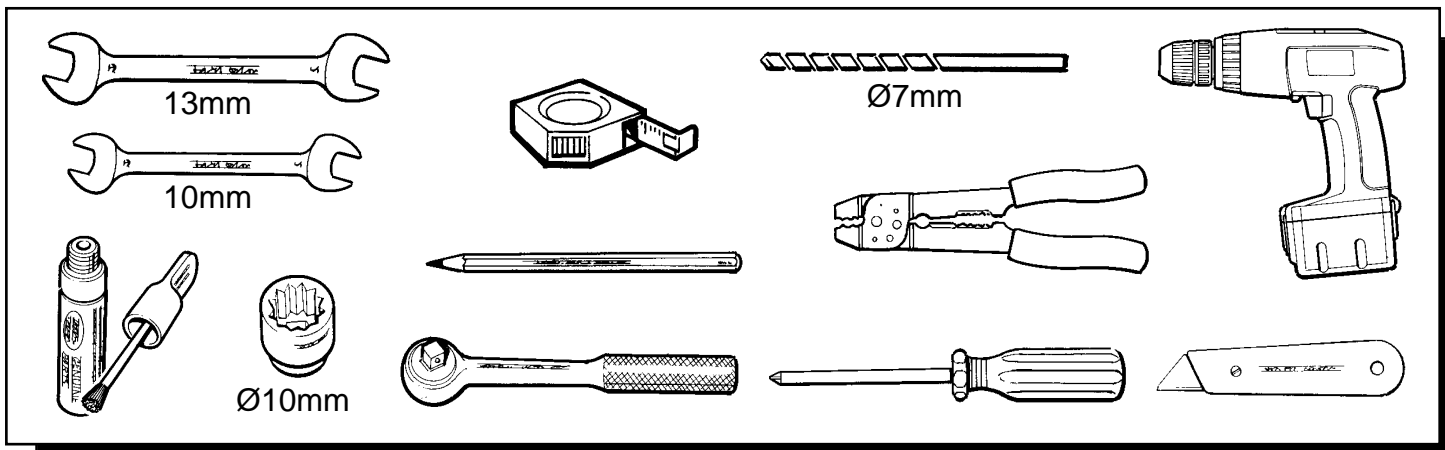
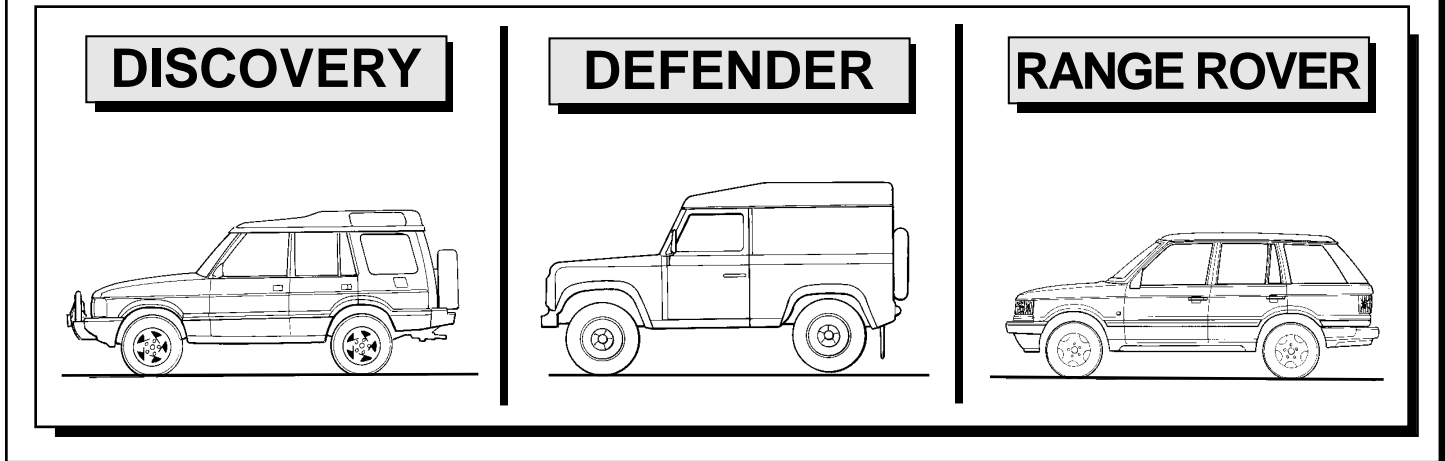
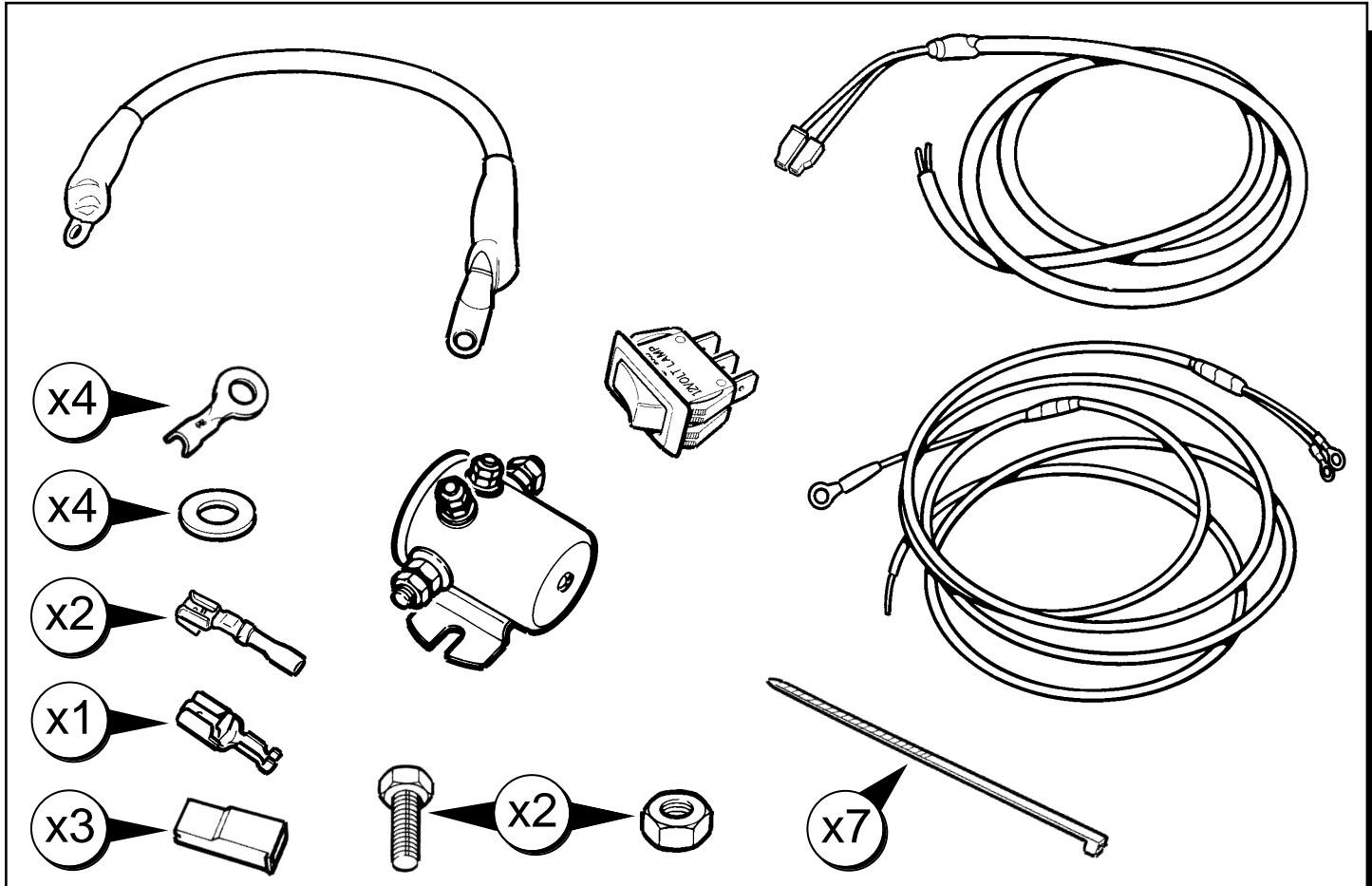

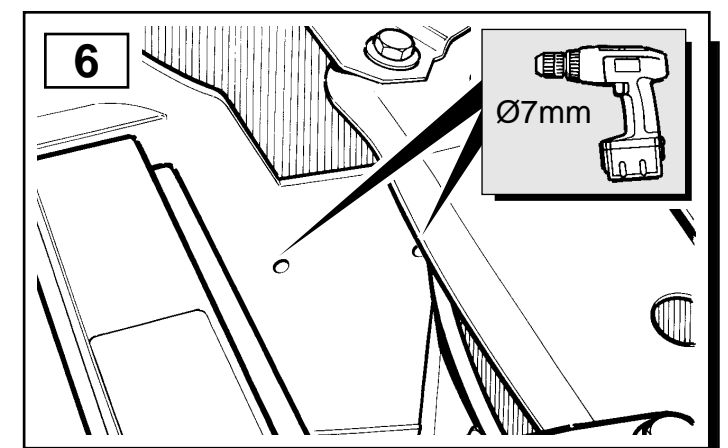
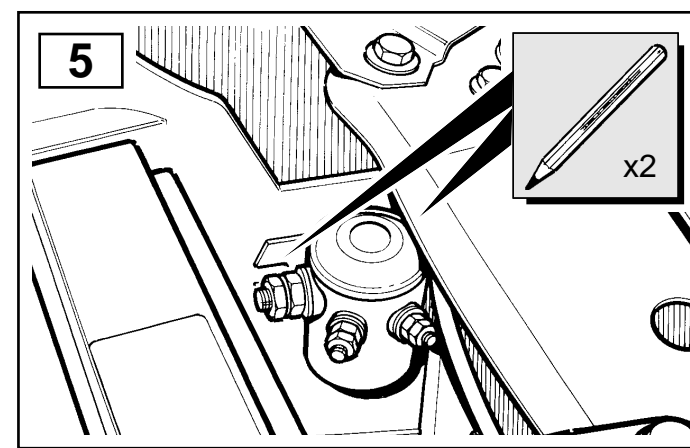
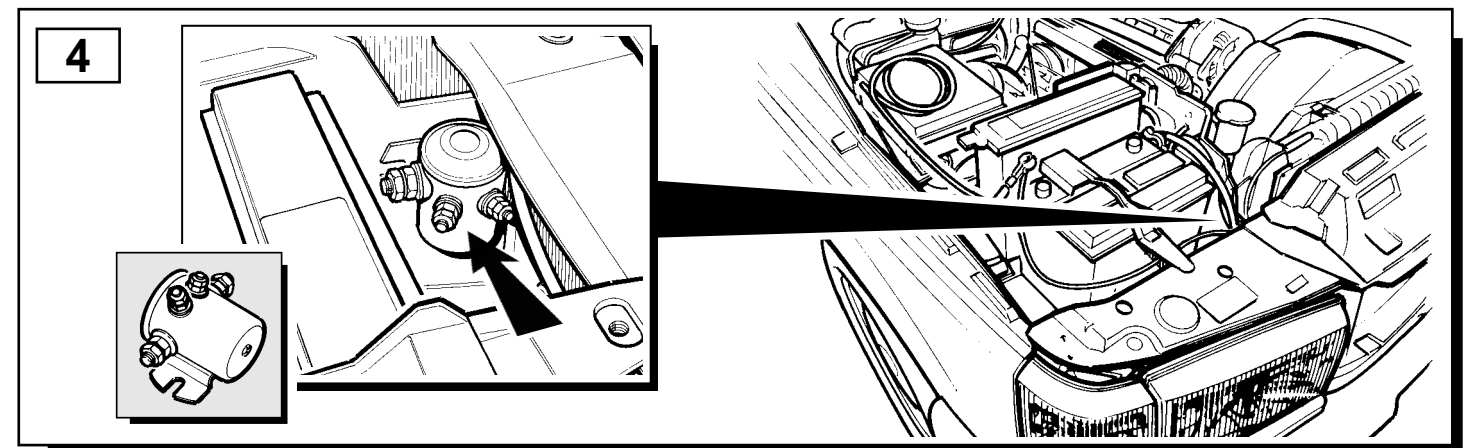
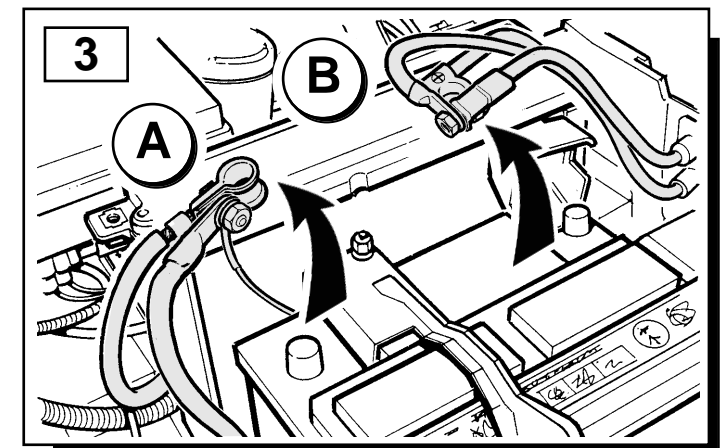
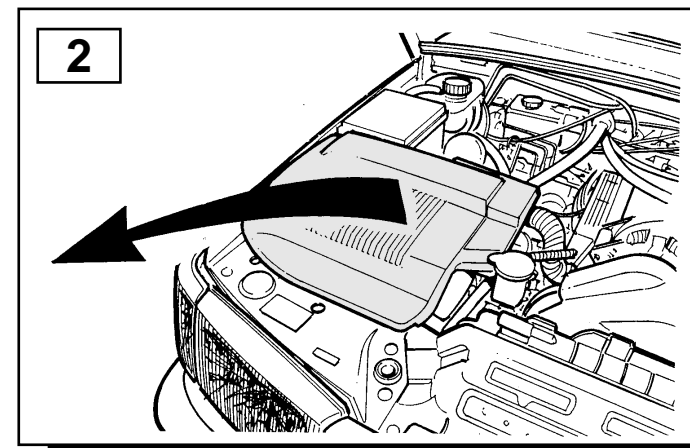
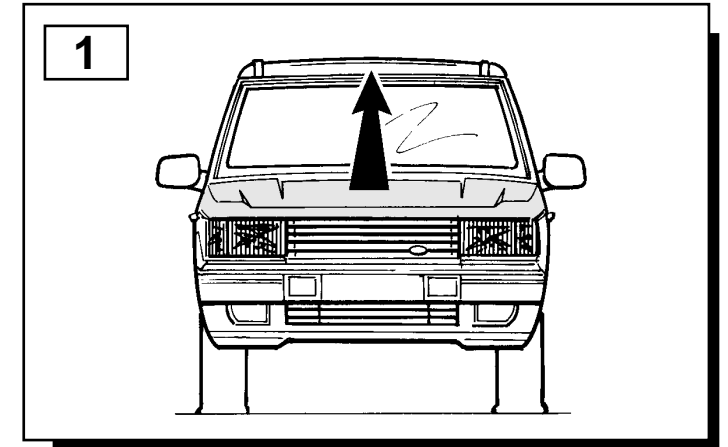
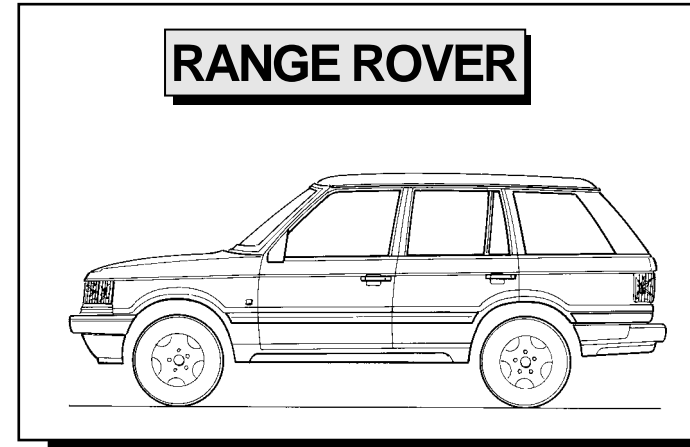
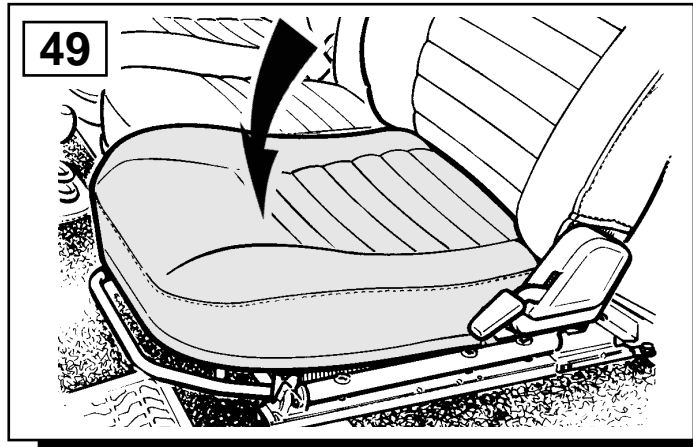



ACCESSORIES

WARNING

Accessories which are not properly fitted can be dangerous. Read the instructions carefully prior to fitting. Whilst fitting, comply with the instructions at all times. If in doubt, contact your nearest Land Rover Dealer.

ACHTUNG!

Nicht sachgemäß montiertes Zubehör kann gefährlich sein. Lesen Sie die Montageanleitung sorgfältig, bevor Sie das Teil montieren. Halten Sie sich bei der Montage an die Anleitung. Bei Unsicherheiten wenden Sie sich bitte an Ihren Land Rover Händler.

AVERTISSEMENT

Les accessoires qui ne sont pas correctement montés risquent d'être dangereux. Veuillez lire soigneusement les instructions avant d'effectuer la pose. Respectez toujours les instructions en cours de pose. En cas de doute, consultez votre concessionnaire Land Rover local.

AVVERTENZA

Gli accessori non sistemati come previsto possono essere pericolosi. Leggere attentamente le istruzioni prima del fissaggio. Durante il montaggio seguire sempre le relative istruzioni. In caso di dubbio rivolgersi al più vicino concessionario della Land Rover.

AVISO

Aquellos accesorios que no hayan sido ajustados debidamente pueden resultar peligrosos. Lea las instrucciones detenidamente antes de iniciar el montaje. Durante el montaje siga las instrucciones en todo momento. En caso de duda póngase en contacto con su Concesionario de Land Rover.

ADVERTÊNCIA!

Os Acessórios que não são montados adequadamente podem ser perigosos. Leia as instruções cuidadosamente antes de montar. Durante a montagem, obedeça as instruções todo o tempo. Se tiver alguma dúvida, contacte o Concessionário LandRover mais próximo.

WAARSHCUWING

Accessoires die niet op de juiste wijze zijn gemonteerd kunnen gevaar opleveren. Lees zorgvuldig de instructies alvorens met de montage te beginnen. Houd u tijdens de montage te allen tijde aan de instructies. Neem bij twijfel contact op met de dichtstbijzijnde Land Rover dealer.

ΠΡΟΕΙΔΟΠΟΙΗΣΗ

Τα προαιρετικά εξαρτήματα που δεν έχουν τοποθετηθεί σωστά μπορεί να είναι επικίνδυνα. Διαβάστε τις οδηγίες πριν προχωρήσετε στην τοποθέτησή τους. Κατά την τοποθέτηση, τηρείτε συνεχώς τις οδηγίες. Αν έχετε οποιαδήποτε αμφιβολία, επικοινωνήστε με τον πλησιέστερο αντιπρόσωπο της.

注意

正しく取り付けられていない備品があると、事故の原因になります。取付ける前にこのマニュアルをよくお読みください。取付けの際は必ずこのマニュアルにある指示に従ってください。何か不明な点がありましたら、お近くのランド・ローバー社のディーラーまでお問い合わせください。



FITTING INSTRUCTION

Fire Extinguisher

EINBAUANLEITUNG

Feuerlöscher

INSTRUCTION DE MONTAGE

Extincteur

ISTRUZIONI PER L'USO

Estintore

INSTRUCCIONES DE MONTAJE

Extintor

INSTRUÇÕES DE MONTAGEM

Extintor de Incêndios

MONTAGEHANDLEIDING

Brandblusser

ΟΔΗΓΙΑ ΤΟΠΟΘΕΤΗΣΗΣ

Πυροσβεστήρας

取付用マニュアル

消火器

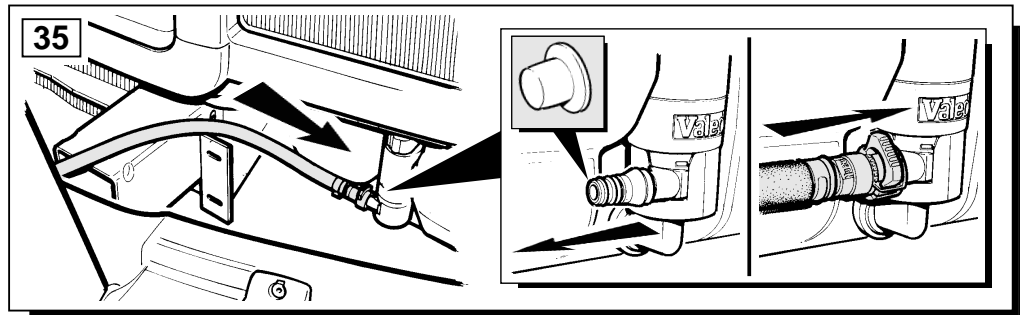
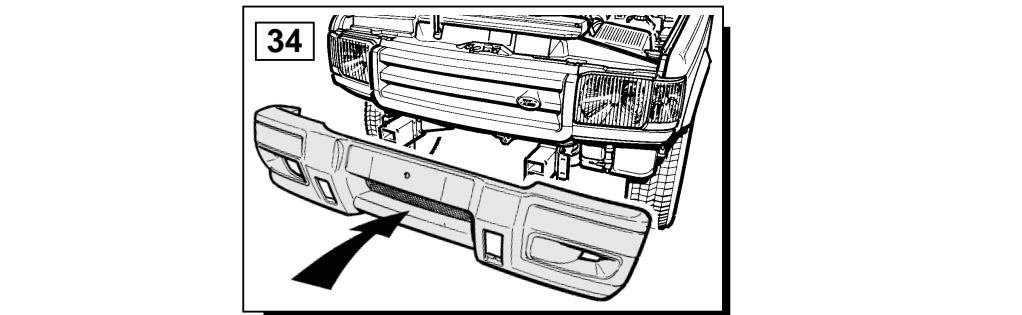
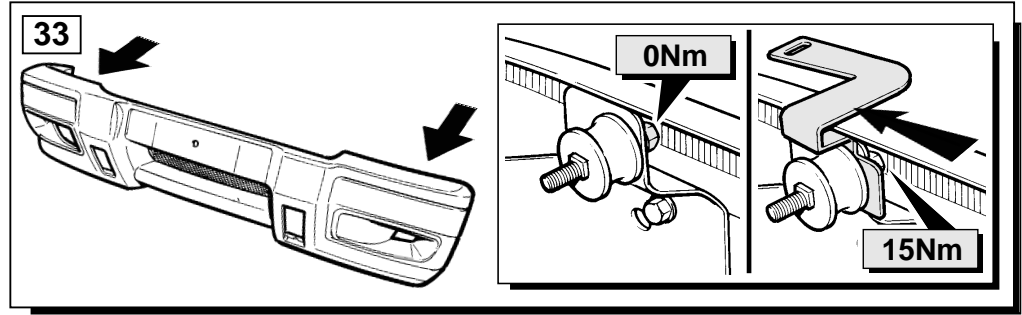
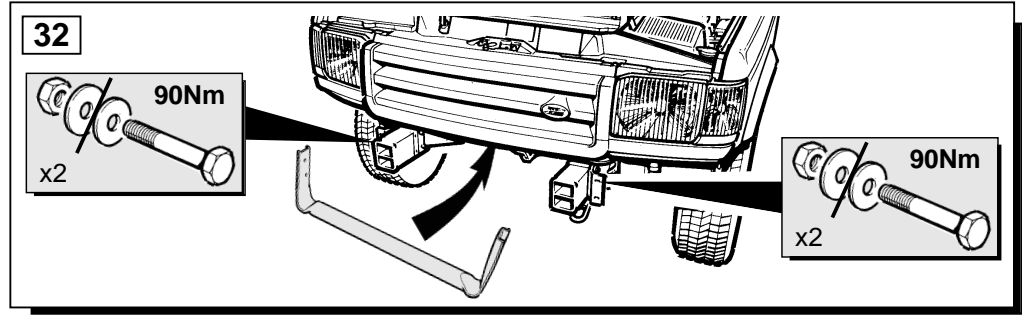
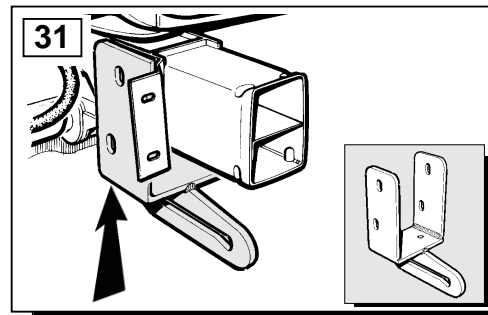
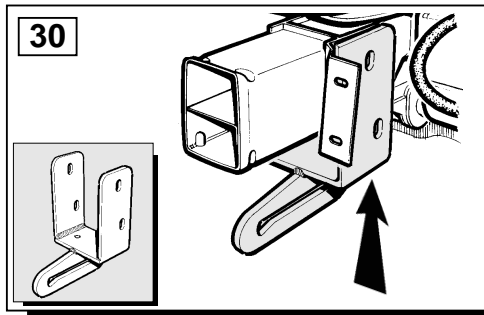
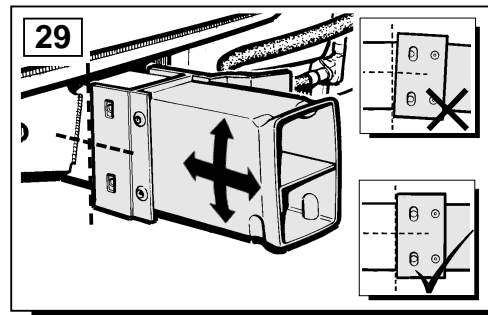
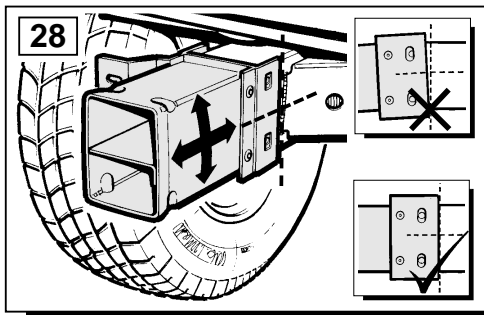
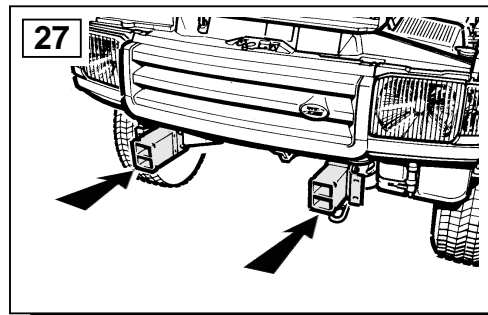
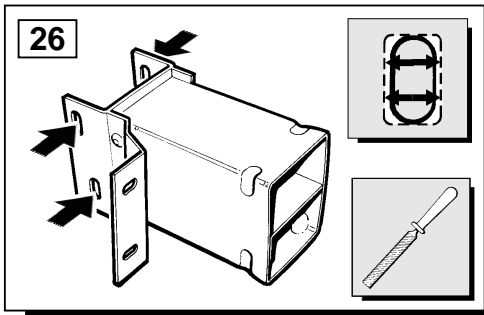
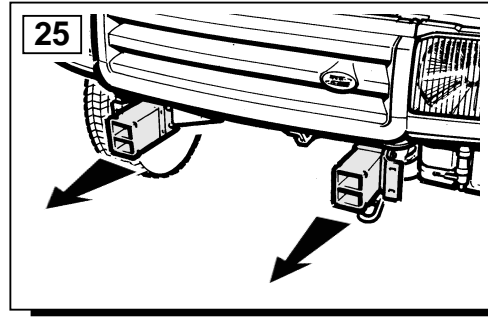
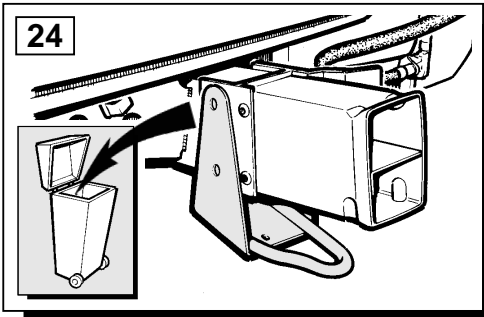

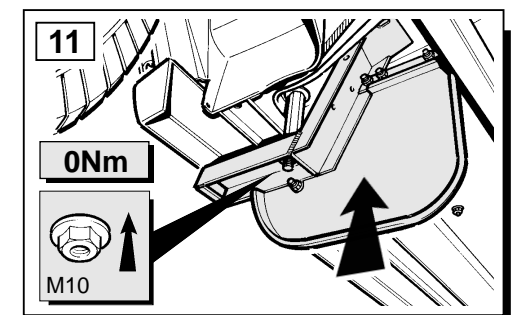
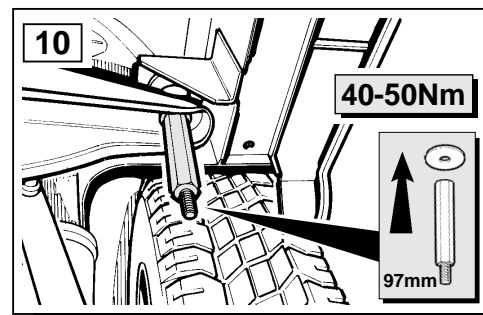
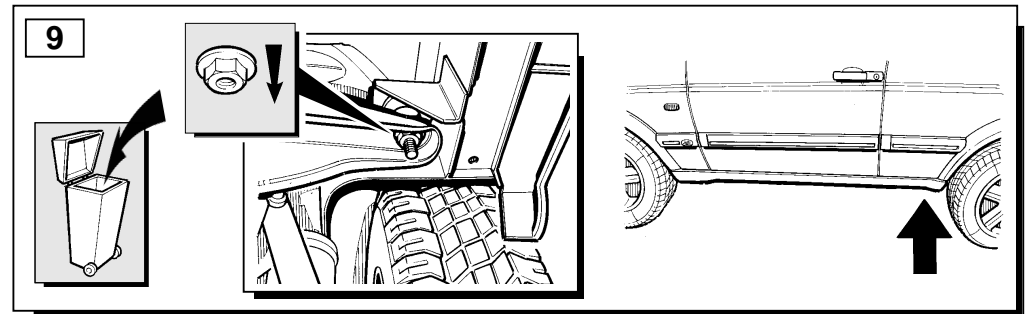
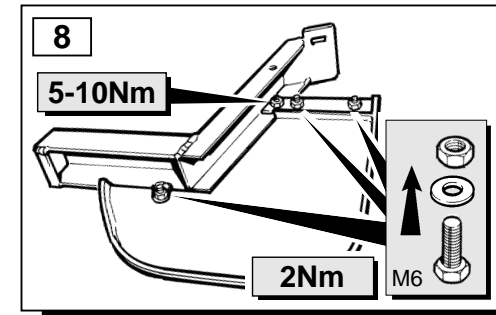
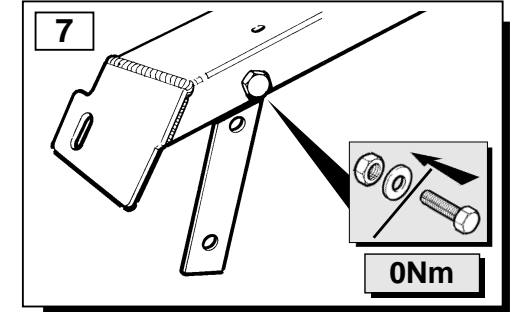
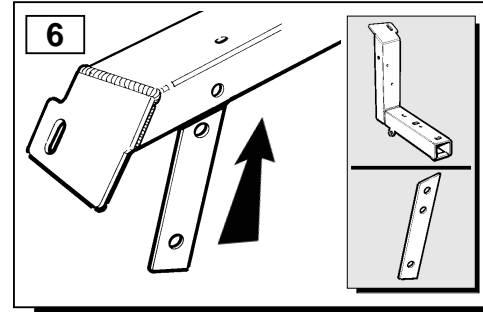
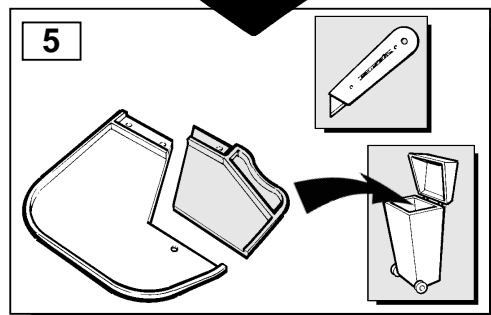
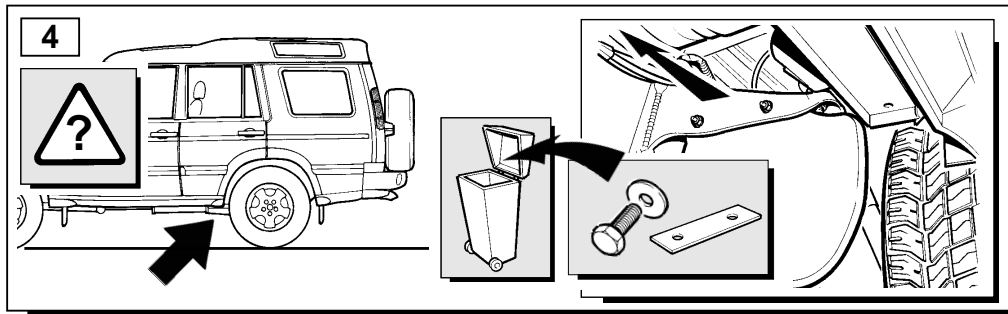
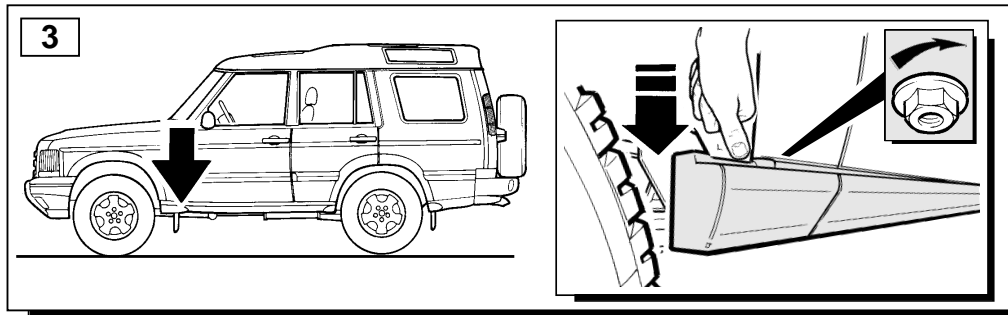
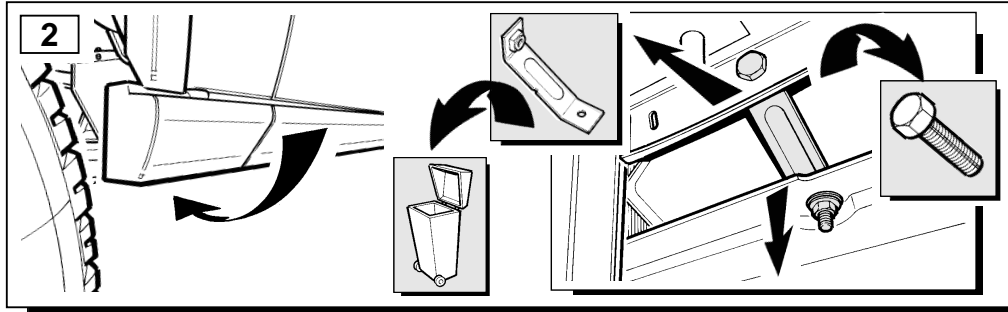



ACCESSORIES

WARNING

Accessories which are not properly fitted can be dangerous. Read the instructions carefully prior to fitting. Whilst fitting, comply with the instructions at all times. If in doubt, contact your nearest Land Rover Dealer.

ACHTUNG!

Nicht sachgemäß montiertes Zubehör kann gefährlich sein. Lesen Sie die Montageanleitung sorgfältig, bevor Sie das Teil montieren. Halten Sie sich bei der Montage an die Anleitung. Bei Unsicherheiten wenden Sie sich bitte an Ihren Land Rover Händler.

AVERTISSEMENT

Les accessoires qui ne sont pas correctement montés risquent d'être dangereux. Veuillez lire soigneusement les instructions avant d'effectuer la pose. Respectez toujours les instructions en cours de pose. En cas de doute, consultez votre concessionnaire Land Rover local.

AVVERTENZA

Gli accessori non sistemati come previsto possono essere pericolosi. Leggere attentamente le istruzioni prima del fissaggio. Durante il montaggio seguire sempre le relative istruzioni. In caso di dubbio rivolgersi al più vicino concessionario della Land Rover.

AVISO

Aquellos accesorios que no hayan sido ajustados debidamente pueden resultar peligrosos. Lea las instrucciones detenidamente antes de iniciar el montaje. Durante el montaje siga las instrucciones en todo momento. En caso de duda póngase en contacto con su Concesionario de Land Rover.

ADVERTÊNCIA!

Os Acessórios que não são montados adequadamente podem ser perigosos. Leia as instruções cuidadosamente antes de montar. Durante a montagem, obedeça as instruções todo o tempo. Se tiver alguma dúvida, contacte o Concessionário LandRover mais próximo.

WAARSHCUWING

Accessoires die niet op de juiste wijze zijn gemonteerd kunnen gevaar opleveren. Lees zorgvuldig de instructies alvorens met de montage te beginnen. Houd u tijdens de montage te allen tijde aan de instructies. Neem bij twijfel contact op met de dichtstbijzijnde Land Rover dealer.

ΠΡΟΕΙΔΟΠΟΙΗΣΗ

Τα προαιρετικά εξαρτήματα που δεν έχουν τοποθετηθεί σωστά μπορεί να είναι επικίνδυνα. Διαβάστε τις οδηγίες πριν προχωρήσετε στην τοποθέτησή τους. Κατά την τοποθέτηση, τηρείτε συνεχώς τις οδηγίες. Αν έχετε οποιαδήποτε αμφιβολία, επικοινωνήστε με τον πλησιέστερο αντιπρόσωπο της.

注意

正しく取り付けられていない備品があると、事故の原因になります。取付ける前にこのマニュアルをよくお読みください。取付けの際は必ずこのマニュアルにある指示に従ってください。何か不明な点がありましたら、お近くのランド・ローバー社のディーラーまでお問い合わせください。



FITTING INSTRUCTION

Occasional Seats

EINBAUANLEITUNG

Gelegentliche Sitze

INSTRUCTION DE MONTAGE

Gelegentliche Sitze

ISTRUZIONI PER L'USO

Sedili occasionali

INSTRUCCIONES DE MONTAJE

Asientos ocasionales

INSTRUÇÕES DE MONTAGEM

Assentos Ocasionalis

MONTAGEHANDLEIDING

Noodzittingen

ΟΔΗΓΙΑ ΤΟΠΟΘΕΤΗΣΗΣ

Καθίσματα Περιστασιακής Χρήσης

取付用マニュアル
予備シート

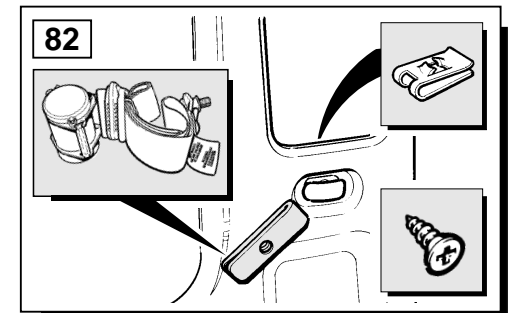
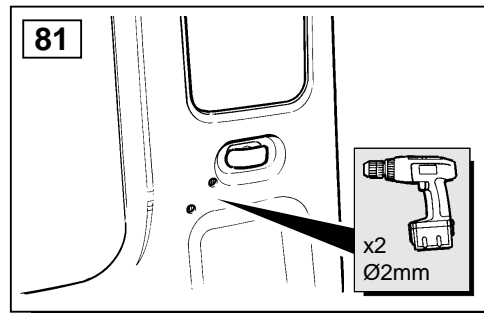
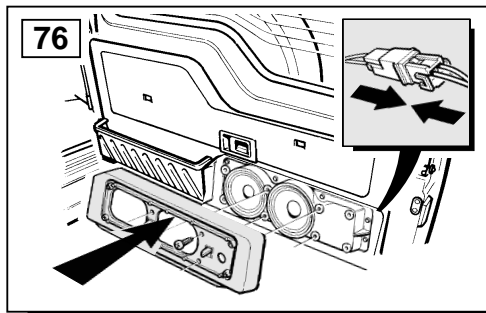
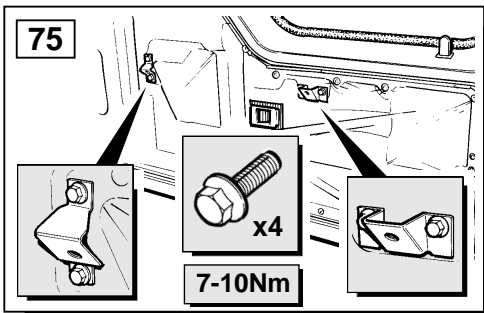
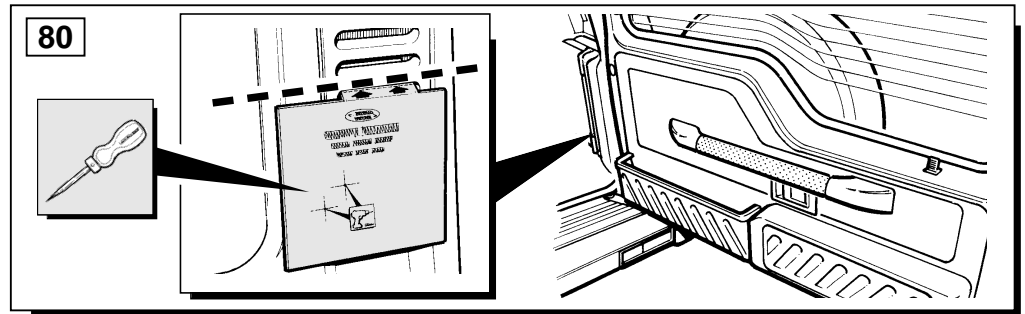
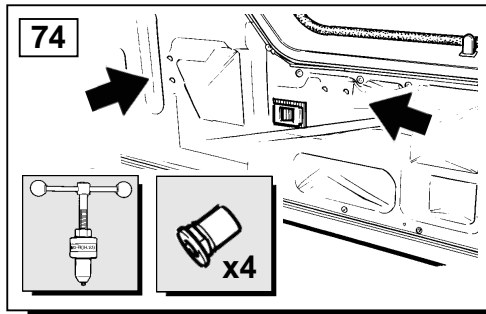
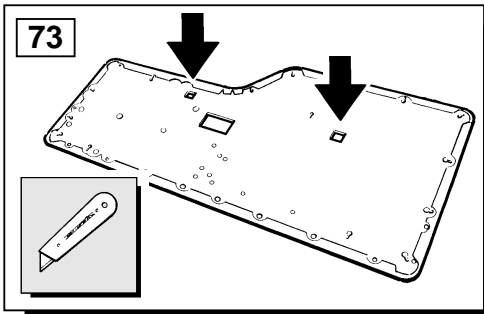
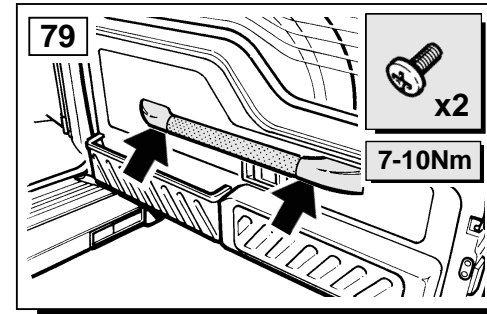
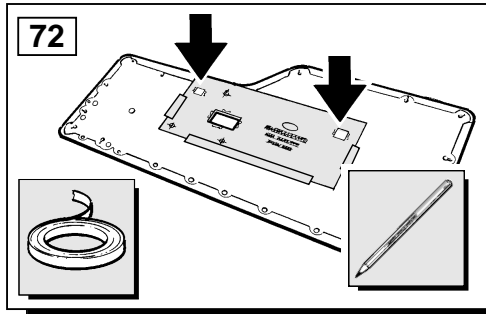
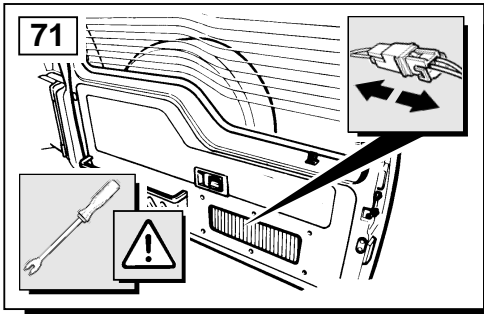
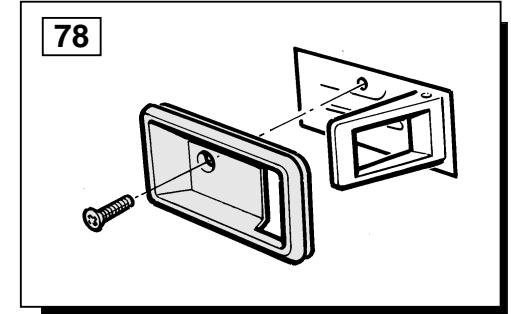
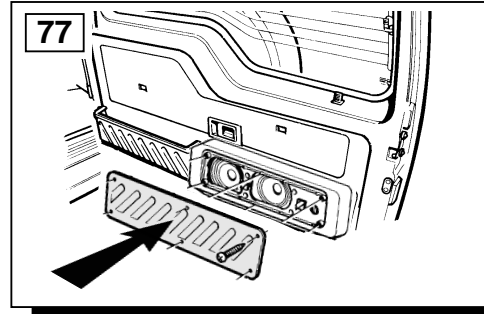
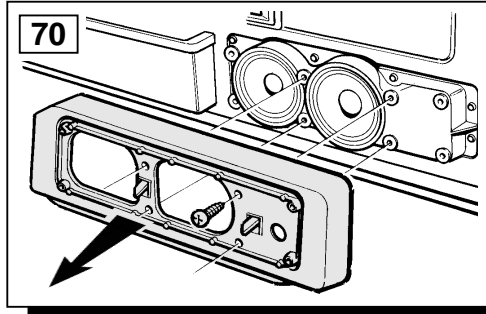
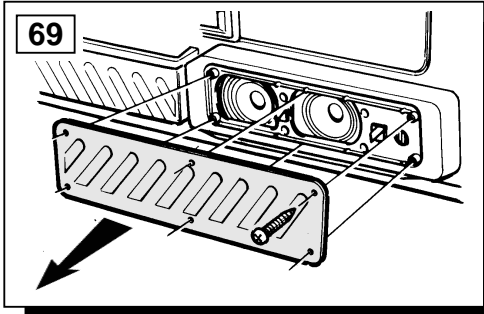



ACCESSORIES

WARNING

Accessories which are not properly fitted can be dangerous. Read the instructions carefully prior to fitting. Whilst fitting, comply with the instructions at all times. If in doubt, contact your nearest Land Rover Dealer.

ACHTUNG!

Nicht sachgemäß montiertes Zubehör kann gefährlich sein. Lesen Sie die Montageanleitung sorgfältig, bevor Sie das Teil montieren. Halten Sie sich bei der Montage an die Anleitung. Bei Unsicherheiten wenden Sie sich bitte an Ihren Land Rover Händler.

AVERTISSEMENT

Les accessoires qui ne sont pas correctement montés risquent d'être dangereux. Veuillez lire soigneusement les instructions avant d'effectuer la pose. Respectez toujours les instructions en cours de pose. En cas de doute, consultez votre concessionnaire Land Rover local.

AVVERTENZA

Gli accessori non sistemati come previsto possono essere pericolosi. Leggere attentamente le istruzioni prima del fissaggio. Durante il montaggio seguire sempre le relative istruzioni. In caso di dubbio rivolgersi al più vicino concessionario della Land Rover.

AVISO

Aquellos accesorios que no hayan sido ajustados debidamente pueden resultar peligrosos. Lea las instrucciones detenidamente antes de iniciar el montaje. Durante el montaje siga las instrucciones en todo momento. En caso de duda póngase en contacto con su Concesionario de Land Rover.

ADVERTÊNCIA!

Os Acessórios que não são montados adequadamente podem ser perigosos. Leia as instruções cuidadosamente antes de montar. Durante a montagem, obedeça as instruções todo o tempo. Se tiver alguma dúvida, contacte o Concessionário LandRover mais próximo.

WAARSHCUWING

Accessoires die niet op de juiste wijze zijn gemonteerd kunnen gevaar opleveren. Lees zorgvuldig de instructies alvorens met de montage te beginnen. Houd u tijdens de montage te allen tijde aan de instructies. Neem bij twijfel contact op met de dichtstbijzijnde Land Rover dealer.

ΠΡΟΕΙΔΟΠΟΙΗΣΗ

Τα προαιρετικά εξαρτήματα που δεν έχουν τοποθετηθεί σωστά μπορεί να είναι επικίνδυνα. Διαβάστε τις οδηγίες πριν προχωρήσετε στην τοποθέτησή τους. Κατά την τοποθέτηση, τηρείτε συνεχώς τις οδηγίες. Αν έχετε οποιαδήποτε αμφιβολία, επικοινωνήστε με τον πλησιέστερο αντιπρόσωπο της.

注意

正しく取り付けられていない備品があると、事故の原因になります。取付ける前にこのマニュアルをよくお読みください。取付けの際は必ずこのマニュアルにある指示に従ってください。何か不明な点がありましたら、お近くのランド・ローバー社のディーラーまでお問い合わせください。



FITTING INSTRUCTION

Mini Roof Rails Kit

EINBAUANLEITUNG

Mini-Dachlastträgersatz

INSTRUCTION DE MONTAGE

Kit de petits longerons de toit

ISTRUZIONI PER L'USO

Corredo piccoli profilati tetto

INSTRUCCIONES DE MONTAJE

Kit de minibarras para el techo

INSTRUÇÕES DE MONTAGEM

Kit de Trilhos Pequenos do Tejadilho

MONTAGEHANDLEIDING

Kleine Dakrail pakket

ΟΔΗΓΙΑ ΤΟΠΟΘΕΤΗΣΗΣ

Κιτ Μίνι Ραγών Οροφής

取付用マニュアル
ミニ ルーフ レール キット

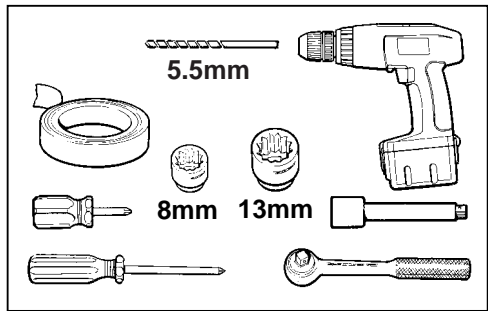
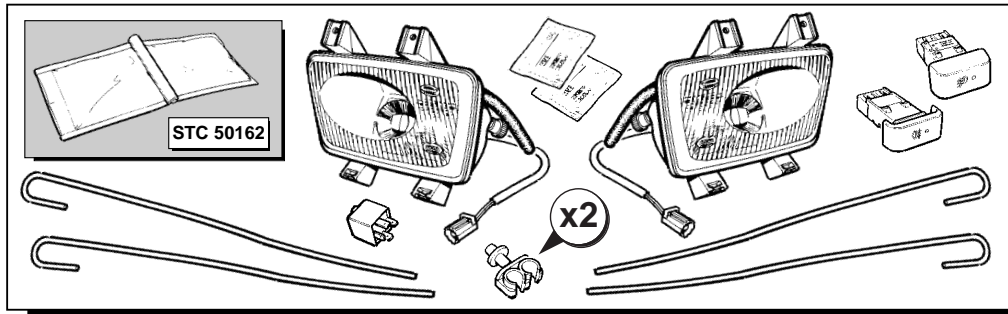
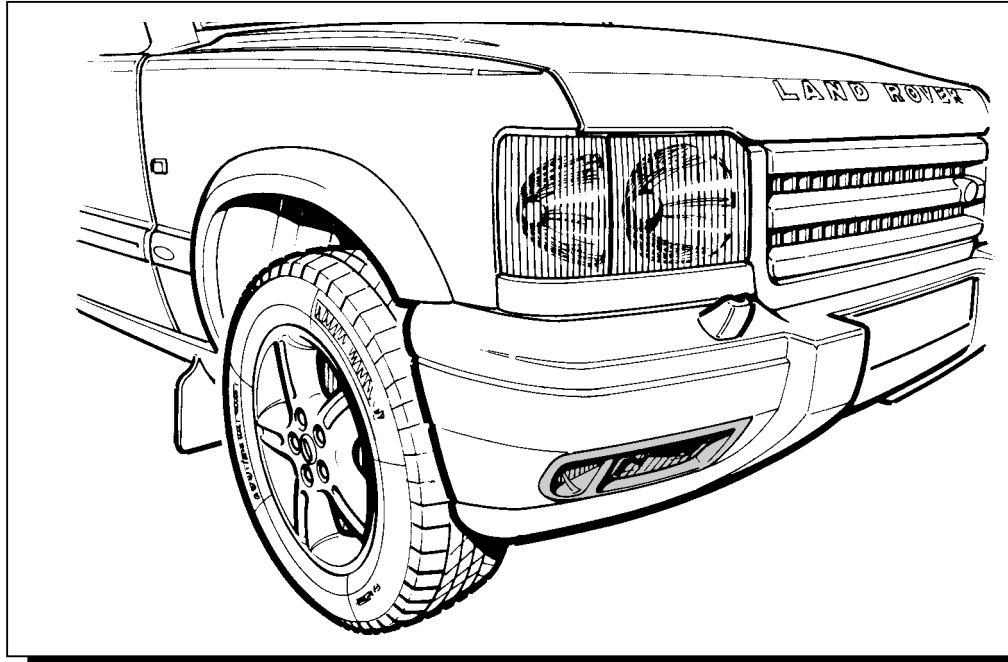

- (GB) Dealer Fit Only.
- (D) Einbau durch Vertragshändler.
- (F) Raccord posé.
- (I) Montaggio fatto da un concessionario.
- (E) Instalación por un concesionario.
- (P) Instalação pelo Concessionário.
- (NL) Montage door de dealer.
- (GR) Τοποθέτηση μόνο από τον Αντιπρόσωπο
- (B) 取付けはディーラーだけが行なうこと。



- (GB) The following instructions are valid for both sides of the vehicle.
- (D) Folgende Anweisungen gelten für beide Fahrzeugseiten.
- (F) Les instructions suivantes sont applicables aux deux côtés du véhicule.
- (I) Le istruzioni seguenti sono valide per entrambe le fiancate della Vettura.
- (E) Las siguientes instrucciones son válidas para ambos lados del vehículo.
- (P) As instruções a seguir aplicam-se a ambos os lados do veículo.
- (NL) De volgende instructies zijn van toepassing op beide zijden van de auto.
- (GR) Οι ακόλουθες οδηγίες ισχύουν και για τις δύο πλευρές του οχήματος.
- (B) 次の取付け方法は車の両サイドに適用できます。

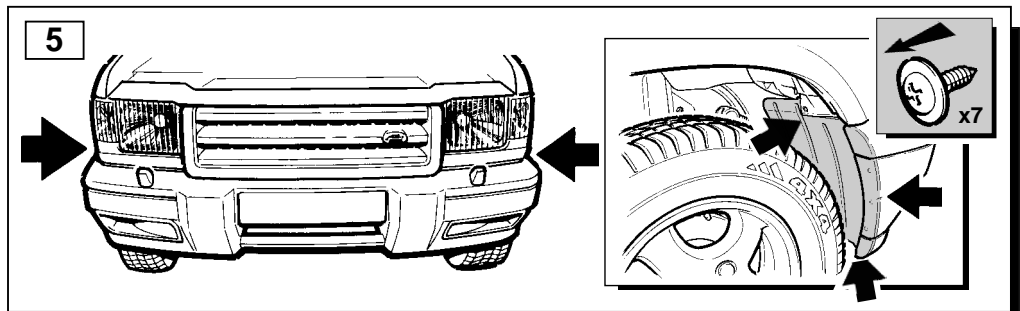
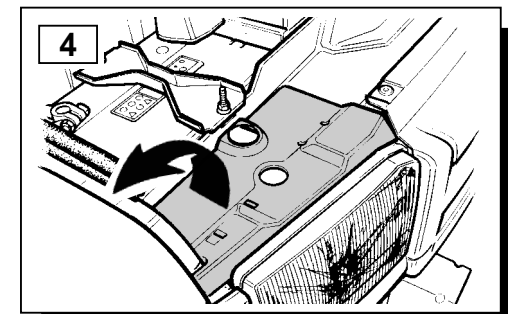
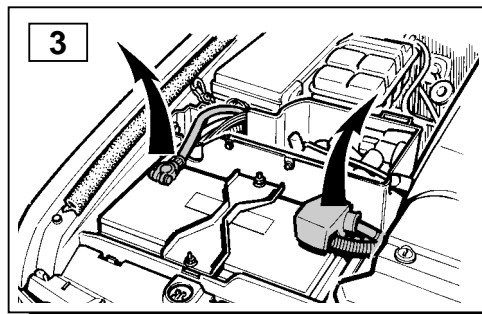
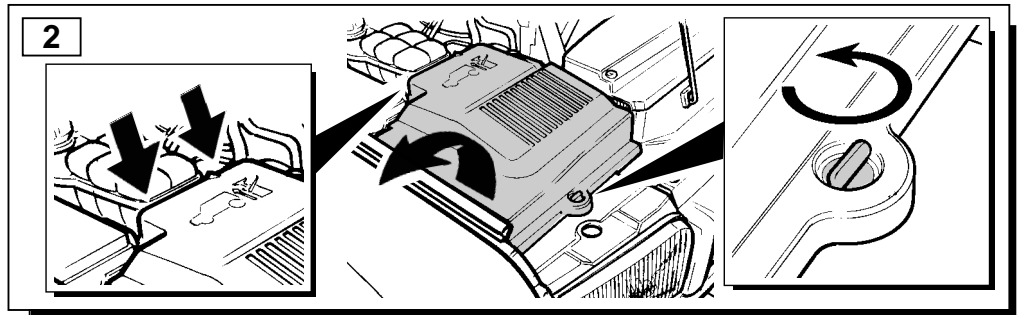
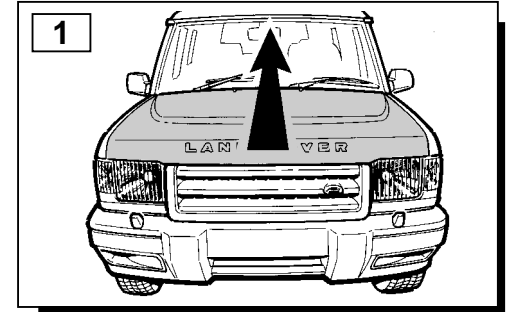

CLICK HERE TO **DOWNLOAD** THE COMPLETE MANUAL

- Thank you very much for reading the preview of the manual.
- You can download the complete manual from: www.heydownloads.com by clicking the link below



- Please note: If there is no response to CLICKING the link, please download this PDF first and then click on it.

CLICK HERE TO **DOWNLOAD** THE COMPLETE MANUAL